

Spring 2017

Supervisor and Subordinate Perceptions of Leader-Member Exchange: Examining Idiosyncratic Deals and Work-Family Experiences in a Moderated Mediation Model

Michael L. Litano
Old Dominion University

Follow this and additional works at: https://digitalcommons.odu.edu/psychology_etds

 Part of the [Industrial and Organizational Psychology Commons](#), and the [Organizational Behavior and Theory Commons](#)

Recommended Citation

Litano, Michael L.. "Supervisor and Subordinate Perceptions of Leader-Member Exchange: Examining Idiosyncratic Deals and Work-Family Experiences in a Moderated Mediation Model" (2017). Doctor of Philosophy (PhD), dissertation, , Old Dominion University, DOI: 10.25777/z9z5-y143
https://digitalcommons.odu.edu/psychology_etds/50

This Dissertation is brought to you for free and open access by the Psychology at ODU Digital Commons. It has been accepted for inclusion in Psychology Theses & Dissertations by an authorized administrator of ODU Digital Commons. For more information, please contact digitalcommons@odu.edu.

**SUPERVISOR AND SUBORDINATE PERCEPTIONS OF LEADER-MEMBER
EXCHANGE: EXAMINING IDIOSYNCRATIC DEALS AND WORK-FAMILY
EXPERIENCES IN A MODERATED MEDIATION MODEL**

by

Michael L. Litano

B.S. June 2009, University of Massachusetts, Amherst

M.A. June 2012, Boston University

M.S. December 2014, Old Dominion University

A Dissertation Submitted to the Faculty of
Old Dominion University in Partial Fulfillment of the
Requirements for the Degree of

DOCTOR OF PHILOSOPHY

INDUSTRIAL ORGANIZATIONAL PSYCHOLOGY

OLD DOMINION UNIVERSITY

May 2017

Approved by:

Debra A. Major (Director)

Xiaoxiao Hu (Member)

Timothy Madden (Member)

ABSTRACT

SUPERVISOR AND SUBORDINATE PERCEPTIONS OF LEADER-MEMBER EXCHANGE: EXAMINING IDIOSYNCRATIC DEALS AND WORK-FAMILY EXPERIENCES IN A MODERATED MEDIATION MODEL

Michael L. Litano
Old Dominion University, 2017
Director: Dr. Debra A. Major

The extant literature recognizes that subordinates in high-quality leader-member exchange (LMX) relationships experience the most favorable outcomes (Dulebohn, Bommer, Liden, Brouer, & Ferris, 2012). In exchange for their unwavering commitment and superior job performance, high LMX subordinates benefit from greater access to valuable resources (e.g., communication, support, and negotiating latitude; Gerstner & Day, 1997), which can then be used to combat job demands and facilitate accomplishment of the subordinates' salient goals (Agarwal, Datta, Blake-Beard, & Bhargava, 2012; Hobfoll, 2001). Meta-analytic evidence suggests that LMX also has critical implications for work-family outcomes (Litano, Major, Streets, Landers, & Bass, 2016), however, the mechanisms through which the LMX relationship influences work-family experiences remain unclear. The present study sought to clarify this process by examining the relationship between LMX and idiosyncratic deals (i-deals) along with resultant work-family experiences. Drawing from social exchange (Blau, 1964), role (Kahn, Wolfe, Quinn, Snoek, & Rosenthal, 1964), and job characteristics (Hackman & Oldham, 1980; Humphrey, Nahrgang, & Morgeson, 2007) theories, it was hypothesized that both flexibility and developmental i-deals are positively related to work-family enrichment, and that flexibility i-deals are negatively related to work interference with family. In addition, given that a key characteristic of i-deals is that they are mutually beneficial and it is the leader who is generally

responsible for authorizing such arrangements, this research sought to incorporate the supervisor's appraisal of the LMX relationship (SLMX) as a moderator in the relationship between subordinate LMX and i-deals. In accord with the dyadic perspective of LMX (Cogliser, Schriesheim, Scandura, & Gardner, 2009; Krasikova & LeBreton, 2012; Wayne, Shore, & Liden, 1997), it was predicted that the indirect relationship between LMX and work-family outcomes via i-deals would be moderated by SLMX, such that work-family experiences would be most optimal at higher levels of supervisor-rated LMX. To examine such a model, multi-source data was collected from 133 matched supervisor-subordinate dyads from a large government organization in the southeastern US. Using Mplus version 7.4 to account for the nested nature of the data, Edwards and Lambert's (2007) path analytic procedures were employed to test the model hypotheses. Although the conditional indirect effect hypotheses were not supported, results suggest that task and schedule flexibility i-deals may be negotiated through high-quality LMX relationships and have advantageous work-family implications. However, LMX was related to work-family outcomes above and beyond i-deals, suggesting that additional LMX-generated resources may play an important role in optimizing work-family management. Furthermore, LMX had differential effects on work-family experiences depending on which dyad member provided the assessment. Holding the effects of all other variables constant, SLMX was positively related to WFE, and LMX was negatively related to WIF. This study's findings make a number of theoretical contributions to the leadership and work-family literatures and may shed light on practical avenues for facilitating employees' work-family management efforts.

Copyright, 2017, by Michael L. Litano and Old Dominion University, All Rights Reserved.

I dedicate this dissertation to my family and many friends. Most of all, I wish to dedicate this dissertation to my father, who continues to inspire me well past his time on Earth. I wish you could be here to share this moment with me, Dad.

ACKNOWLEDGMENTS

I would like to express my deepest gratitude to my advisor, Dr. Debra Major, who helped to instill in me the work ethic that now differentiates me from my peers. Throughout our four-plus years together, she challenged me to be the best version of myself and, in doing so, prepared me to be a competitive and well-rounded Industrial-Organizational Psychologist. She has been instrumental in my professional and personal development, and her I strive to embody her leadership style as I progress in my career. Our relationship was representative of our program of research; as the quality of our relationship developed, I earned and was afforded opportunities and resources that facilitated my pursuit of career and personal life goals. I can only hope that I lived up to my end of the reciprocal exchange process.

I would also like to extend my thanks to my committee members, Dr. Xiaoxiao Hu and Dr. Timothy Madden, who have each played critical and unique roles in my professional development, and in the progress of this research project. I thank you from the bottom of my heart for volunteering your time to serve on my dissertation committee and for mentoring me throughout my graduate career.

This research would not be possible without my mentors, Dr. Anna-Maria McGowan, Dr. Peter Parker, and Laura Rogers. My time working alongside you has been instrumental in shaping my career path. I have learned more from my experiences with you as my mentors than I ever could have hoped for in a standard I-O Psychology internship. You each treated me as a colleague from the first day we met and provided me the autonomy to develop a customized research experience. I thank you all for the ways you each contributed to my professional development.

I would specifically like to recognize some peers and colleagues who played particularly influential roles in my graduate career. First and foremost, Ben Bass. I can honestly say that I don't think I have ever met a more intelligent individual in my life – it's our late-night conversations when we should *not* have been discussing I-O Psychology that we came up with some of our most 'genius' ideas. Without your support and friendship, I wouldn't have been able to make it this far in the program. I am excited for the day that we can start our own consulting company – and don't worry, I'll do all the talking. I love you, buddy.

In addition, I'd like to specifically recognize Matt Byers, Andrew Collmus, Ralitsa Maduro, Kellie Kennedy, Val Streets, and Dante Myers, who have all acted as a strong support system for me throughout my time at Old Dominion University. My friends from Massachusetts have been extremely understanding, supportive, and forgiving throughout this process. Steve Ray, Tim Nelligan, and Dustin Burdette – thank you for continuing to be my friend even when I fall out of touch for months on end. You are very much appreciated, and I love you guys.

Finally, this work would not be possible without the love, support, encouragement, and sacrifices of my family. To Otis, I am sorry that I was too poor to bring you to doggy daycare multiple times per week. I know you love me anyway, and to show my thanks, a backyard is in your near future. To my beautiful little sisters, Anna and Cady, I hope that in some way the time that I was not able to spend with you over the past four years inspires you to pursue your dreams even if they are outside your comfort zone. You are both smart, talented, and hilarious, and I hope you never change. To my aunt (cousin) Marie. Your open home has showed me the true meaning of family. Your love and support helped me persevere through this program through this program despite all of the losses this family incurred. Thank you, and I love you. To my sister, Kate – I love how our relationship continues to grow every year. I look up to you. You are never allowed to live this far away from me, again. To my mother, Linda. Mom, I never would be here without you. From a very early age, you instilled in me a sense of confidence that I was intelligent. I don't know how you tricked me into believing that, but when all else went wrong, I was able to 'fall back' on that. You sacrificed so much for Kate and I growing up – I will never be able to repay you, but I hope you will accept my love and gratitude instead. And finally, the love of my life, Kate (yes, another one). I have never met a kinder, more patient, and loving person than you. Your empathy and support kept me sane during the many emotional roller-coasters that graduate school brought, and your love inspired me to be a better and more caring person every day. I cannot wait to move on to the next stage of our lives together. I love you.

TABLE OF CONTENTS

	Page
LIST OF TABLES	vi
LIST OF FIGURES	vii
Chapter	
I. INTRODUCTION	1
THE WORK-FAMILY INTERFACE	7
LEADER-MEMBER EXCHANGE THEORY	10
UNDERSTANDING WORK-FAMILY THROUGH LMX	12
NEGOTIATING FOR OPTIMAL WORK-FAMILY EXPERIENCES	20
IDIOSYNCRATIC DEALS	20
THE LEADER AS A NEGOTIATING PARTNER	39
EXPLORING LMX CONGRUENCE	45
II. METHOD	48
PARTICIPANTS AND PROCEDURES	48
MEASURES	50
III. RESULTS	58
POWER ANALYSIS	58
DATA ANALYTIC STRATEGY	59
MEASUREMENT MODEL	63
PATH MODEL AND HYPOTHESIS TESTING	67
ADDITIONAL ANALYSES	98
IV. DISCUSSION	105
V. CONCLUSIONS	127
REFERENCES	128
APPENDICES	
A. WORK INTERFERENCE WITH FAMILY SCALE	155
B. WORK-TO-FAMILY ENRICHMENT SCALE	156
C. IDIOSYNCRATIC DEALS SCALE	157
D. SUBORDINATE-RATED LEADER-MEMBER EXCHANGE SCALE	158
E. SUPERVISOR-RATED LEADER-MEMBER EXCHANGE SCALE	159
F. THE HYPOTHESIZED MODEL WITH ALL PATHS DEPICTED	160
G. THE HYPOTHESIZED MODEL CONTROLLED FOR WORK HOURS	161
VITA	162

LIST OF TABLES

Table	Page
1. Comparison of Model Fit for Idiosyncratic Deals Scale	56
2. Descriptive Statistics and Intercorrelations	60
3. Intraclass Correlation Coefficients	62
4. Comparison of Model Fit for Hypothesized Model.....	65
5. Hierarchical Multiple Regression of I-Deals on Leader-Member Exchange	79
6. Model Conditional Indirect Effects for Work-Family Enrichment	84
7. Model Conditional Indirect Effects for Work Interference with Family	85
8. Polynomial Regression of Work-Family Experiences on LMX Congruence	89
9. Polynomial Regression of Flexibility I-deals on LMX Congruence	92
10. Polynomial Regression of Developmental I-deals on LMX Congruence	95
11. Model Conditional Indirect Effects for WFE without Controls	100
12. Model Conditional Indirect Effects for WIF without Controls	101

LIST OF FIGURES

Figure	Page
1. Hypothesized Moderated Mediation Model	5
2. Conceptual Moderated Mediation Model	6
3. Hypothesized Interaction Effects of LMX and SLMX on Idiosyncratic Deals	43
4. Measurement Model	66
5. Hypothesized Model Trimmed for Non-Significant Paths	70
9. Interactive Effects of LMX and SLMX on Work-Family Experiences	73
10. Simple Slopes Analysis for Effects of LMX and SLMX on WFE	74
11. Simple Slopes Analysis for Effects of LMX and SLMX on Career I-deals	80
12. Conceptual Model Depicting Moderated Mediation Model Path Specification	82
13. Response Surface Model of LMX Congruence Effects on WFE	90
14. Response Surface Model of LMX Congruence Effects on WIF	91
15. Response Surface Model of LMX Congruence Effects on Schedule I-deals	93
16. Response Surface Model of LMX Congruence Effects on Location I-deals	94
17. Response Surface Model of LMX Congruence Effects on Task I-deals	96
18. Response Surface Model of LMX Congruence Effects on Career I-deals	97

CHAPTER I

INTRODUCTION

Achieving balance in one's work and family roles is widely recognized as a desirable, yet complex challenge (Greenhaus & Allen, 2011; Major, Burke, & Fiskensbaum, 2013). The work-family literature has traditionally characterized work and family roles as competing for resources (Greenhaus & Parasuraman, 1999), and the tendency for some researchers to equate work-family balance with the absence of conflict has resulted in multiple and inconsistent construct definitions (Carlson, Grzywacz, & Zivnuska, 2009; Wayne, Butts, Casper, & Allen, 2015). This is problematic because such a view largely ignores the positive outcomes associated with involvement in multiple life roles (Greenhaus & Parasuraman, 1999; Greenhaus & Powell, 2006). In the broadest sense, work-family balance refers to "achieving satisfying experiences in all life domains, and to do so requires personal resources such as energy, time, and commitment to be well distributed across domains" (Kirchmeyer, 2000, p. 81). However, work-family balance does not necessitate an equal distribution of resources across roles; rather, perceptions of balance vary based on one's self-assessment that he or she possesses adequate resources to pursue salient goals related to work and family at that particular time (Major & Litano, 2014). Individual perceptions of work-family balance differ across individuals and change over time and life stage (Litano, Myers, & Major, 2014). For example, an individual may find career-related goals (e.g., promotions and salary increases) to be salient at certain life stages, whereas he or she may value family-oriented goals (e.g., coaching child's basketball team) at another.

Over the past three decades, changes in workforce demographics have caused employers' to be more cognizant of employees' changing work-family needs (Allen, Johnson, Kiburz, & Shockley, 2013). Today's employees are often burdened with finding creative ways to navigate work and family due in part to an increased responsibility for both child and elder care (e.g., Hill

et al., 2008; Martinengo, Jacob, & Hill, 2010) and the desire to lead a fulfilling personal life (Casey & Grzywacz, 2008). Organizations have embraced a supporting role in this endeavor, providing formal family-friendly policies that go beyond those required by law (Major, Burke, et al., 2013; Swody & Powell, 2007). However, universal policies designed to facilitate work-family balance may not be appropriate as employees' work-family needs are highly idiosyncratic (Kelly & Kalev, 2006; Lauzun, Morganson, Major, & Green, 2010). Furthermore, access to and use of such policies tends to be contingent on managerial discretion (Kelly & Kalev, 2006).

Coupled with literature suggesting that formal work-family policies are most utilized and successful at optimizing work-family experiences in the presence of managerial and organizational support (Thompson, Beauvais, & Lyness, 1999; Thompson & Prottas, 2006), it is unsurprising that researchers have actively drawn from the leadership literature to understand employees' work-family experiences (Major & Cleveland, 2007; Major & Morganson, 2011). In particular, researchers have demonstrated the relevance of leader-member exchange (LMX) theory as a framework for understanding how leaders influence employees' work-family experiences (Major, Fletcher, Davis, & Germano, 2008; Major & Morganson, 2011). An alternative to early characterizations of leader behavior as consistent across all subordinates (Dansereau, Alutto, & Yammarino, 1984), LMX theorizes that supervisors develop unique relationships with each subordinate and that LMX quality varies across employees (Graen & Uhl-Bien, 1995). Leaders provide high-LMX subordinates with greater access to resources, which can then be used to facilitate work-family management (Major & Morganson, 2011).

Despite ample evidence that LMX is advantageous for work-family outcomes (e.g., Litano et al., 2015), there is a dearth of research examining the mechanisms through which these effects occur. The present study aims to clarify this process by incorporating the literature

surrounding the negotiation of idiosyncratic deals (i-deals), or specialized work arrangements negotiated between an employer and employee for mutual benefit (Rousseau, 2001), and subsequent work-family experiences. Theoretically, subordinates in higher-quality LMX relationships should benefit from being afforded greater negotiating latitude (Dienesch & Liden, 1986; Gerstner & Day, 1997) through which they may be able to tailor their work role to better align with their work and family needs. However, the leader's perspective is noticeably lacking in the leadership and work-family literature. Given that it is the leader who generally has discretion over authorizing such specialized work arrangements (Hornung, Rousseau, & Glaser, 2009; Lauzun et al., 2010), this research incorporates the supervisor's appraisal of LMX as a moderator in the relationship between subordinate LMX and i-deals (see Figure 1).

The current study makes a number of contributions to both theory and practice. First, this study is one of the first studies to examine the underlying processes by which the LMX relationship is related to work-family experiences by positioning i-deals as a mediator of these relationships. The study findings may provide practical guidance to managers seeking to facilitate work-family management. Second, this study is the first to examine how supervisor-rated LMX impacts i-deals. Since the distinguishing feature of LMX theory is its focus on the reciprocal relationship between a supervisor and each subordinate, the extant research incorporating leadership theory as an explanation for i-deals is inadequate as the leader's perspective is currently lacking. Finally, this paper examines supervisor-rated LMX as a moderator of the relationship between subordinate-rated LMX and work-family experiences via i-deals as a way to understand the interplay between each parties' perspective of LMX and subsequent work-family outcomes. The following sections discuss the work-family constructs of interest in the current study and review the literature on leadership as it relates to role negotiation

and the work-family interface. Specific hypotheses related to the relationship between LMX, idiosyncratic deals, and work-family experiences are also presented.

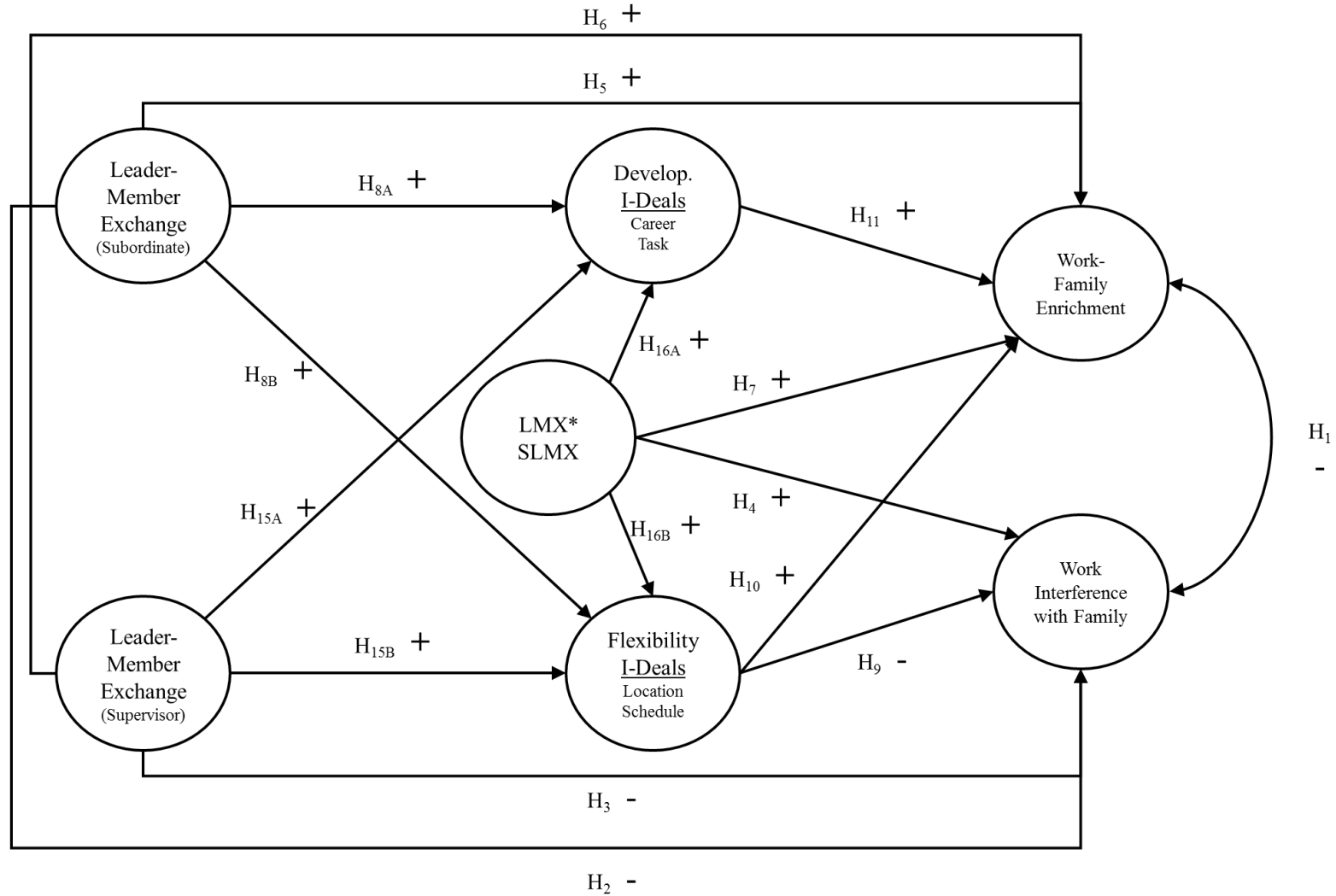

Figure 1. The hypothesized moderated mediation model. The indirect effect hypotheses (H_{12} , H_{13} , H_{14} , and H_{17}) are not depicted. I-deals = Idiosyncratic deals, LMX*SLMX = Interaction between subordinate-rated and supervisor-rated LMX.

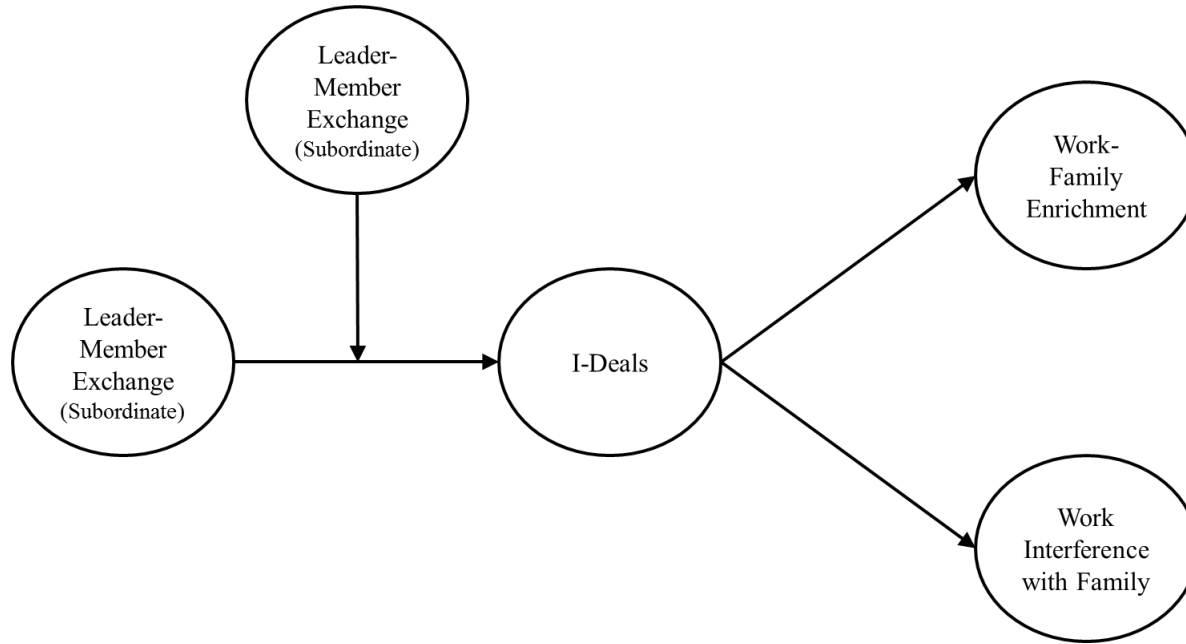

Figure 2. Conceptual model depicting supervisor-rated LMX moderating the indirect effects between subordinate-rated LMX and work-family experiences via idiosyncratic deals.

The Work-Family Interface

National surveys indicate the intersection of work and family to be one of the primary stressors impacting workers' lives today (e.g., American Psychological Association, 2014; Matos & Galinsky, 2014). The work-family interface has primarily been described in terms of *work-family spillover*, or the extent to which experiences, attitudes, and moods transfer between one's work and family roles (Crouter, 1984; Greenhaus & Beutell, 1985). Work-family spillover can manifest as either positive or negative (Greenhaus & Beutell, 1985), and that characterization is largely based upon whether participation in one life role facilitates or hinders performance in the other (Greenhaus & Powell, 2006).

Work-family conflict. Rooted in role theory (Kahn et al., 1964) and representing the negative side of the work-family interface (Grzywacz & Marks, 2000), work-family conflict is defined as a “form of inter-role conflict in which the role pressures from the work and family domains are mutually incompatible” (Greenhaus & Beutell, 1985, p. 77). Work-family conflict manifests when participation in one role impedes the fulfillment of expectations or responsibilities associated with another role (Thomas & Ganster, 1995). Work-family conflict originates from a scarcity perspective; that is, it assumes that individuals possess a finite amount of resources (e.g., time, energy) and therefore posits that working adults who participate in multiple life roles will inevitably experience interrole conflict and strain (Greenhaus & Parasuraman, 1999; Kirchmeyer, 1992).

The work-family conflict construct is bi-directional in nature, such that work role demands can interfere with family life (i.e. work interference with family; WIF) and familial or personal responsibilities can interfere with work life (i.e. family interference with work; FIW; Netemeyer, Boles, & McMurrian, 1996). The source of conflict may be time-based (i.e., time

requirements of one role interfere with participation in the other), strain-based (i.e., stress or strain experienced in one role interferes with participation in the other), or behavior-based (i.e., behaviors required in one role are incompatible with behavioral expectations in the other role; Carlson, Kacmar, & Williams, 2000; Greenhaus & Beutell, 1985). Evidence from a recent meta-analysis suggests that both WIF and FIW are negatively related to a host of adverse work-related outcomes (e.g., job performance, work satisfaction, organizational citizenship behaviors), family-related outcomes (e.g., marital satisfaction, family stress), and health-related outcomes (e.g., life satisfaction, psychological well-being, physical health; Amstad, Meier, Fasel, Elfering, & Semmer, 2011). Further research suggests that WIF transpires more frequently than FIW (Frone, Yardley, & Markel, 1997; Pleck, 1977), and that directional work-family conflict is more heavily influenced by role stressors in the originating domain (i.e., the magnitude of the relationship between job stress and WIF is greater than that between job stress and FIW; Amstad et al., 2011; Michel, Kotrba, Mitchelson, Clark, & Baltes, 2011). For those reasons, this study focuses on WIF due to its interest in the supervisor-subordinate relationship.

Work-family enrichment. Work-family enrichment represents positive work-family spillover, and refers to, “the extent to which experiences in one role improve the quality of life in the other role” (Greenhaus & Powell, 2006, p. 73). Work-family enrichment may originate in either the work (work-to-family enrichment, WFE) or family (family-to-work enrichment, FWE) domain (Greenhaus & Powell, 2006). Both directions of enrichment are positively related to advantageous outcomes, including job, family, and life satisfaction (McNall, Nicklin, & Masuda, 2010). Work-family enrichment transpires when resources generated in one role (i.e., work) enhance one’s performance in another life role (i.e., family; Carlson et al., 2006). In the work-to-family direction, WFE has three forms; work-to-family affect refers to when resource gains

generated from work involvement results in positive emotions or attitudes that help the employee to be a better family member; work-to-family capital refers to resources gains stemming from work participation enhances one's psychosocial resources (e.g., self-efficacy, self-fulfillment, resilience), which then facilitate familial performance; and work-to-family development refers to resource gains in the form of acquired knowledge, skills, perspectives, or behaviors that promote higher levels of functioning in the family domain (Carlson et al., 2006).

Work-family enrichment occurs via two pathways; work-family affect occurs via the affective pathway, and work-family capital and development transpire via the instrumental pathway (Carlson et al. 2006; Greenhaus & Powell, 2006). In the instrumental pathway, resources generated from participation in one's work role are directly applied to improve performance at home. For example, employees might develop interpersonal skills at work that, when applied to their family role, enable them to be better parents and spouses. WFE may also transpire indirectly through an affective pathway when resources gained from work involvement facilitate functioning in the family role through enhanced positive affect (Carlson et al., 2006; Greenhaus & Powell, 2006).

Greenhaus and Powell (2006) identified five types of resources that may be generated through in-role experiences; skills and perspectives, psychological and physical resources, social capital, flexibility, and material resources. Whereas work-family conflict is derived from a scarcity perspective, work-family enrichment recognizes that multiple role involvement can facilitate resource generation and result in beneficial outcomes (i.e., expansionist perspective; Barnett & Baruch, 1985). Although the two constructs share a strong negative relationship, both theory and empirical studies have distinguished work-family enrichment from work-family conflict (Carlson et al., 2006; Frone, 2003). Together, work-family conflict and enrichment act as

the primary antecedents of work-family balance satisfaction and effectiveness (Wayne et al., 2014). It is expected that WIF and WFE will share a strong negative relationship in the current study.

Hypothesis 1: WIF and WFE will be negatively related.

Leader-Member Exchange Theory

Although research suggests that leadership at all organizational levels has an impact on employees' work-family experiences, immediate supervisors are especially influential as the most proximal representative of the organization (Kossek, Pichler, Bodner, & Hammer, 2011; Major et al., 2008). Over the past two decades, researchers have increasingly incorporated traditional leadership theory to develop a better understanding of employees' work-family experiences (Bernas & Major, 2000; Major & Morganson, 2011). In particular, research has demonstrated leader-member exchange (LMX) theory to be a particularly relevant framework for understanding the supervisor's role in this process (Litano et al., 2016; Major et al., 2008).

Derived from role (Kahn et al., 1964) and social exchange (Blau, 1964) theories, LMX describes the quality of the reciprocal exchange relationship between a supervisor and each of his or her subordinates (Gerstner & Day, 1997). Presented as an alternative to theories describing leader behavior as consistent across all employees (Dansereau, Graen, & Haga, 1975), LMX posits that supervisors develop unique relationships with each subordinate and that each relationship varies in quality (Graen & Scandura, 1987; Graen & Uhl-Bien, 1995).

The LMX development process is characterized by three distinct phases: role-taking, role-making, and role-routinization (Graen & Scandura, 1987). During the role-taking stage of the dyadic relationship, the supervisor evaluates the subordinate's skills, capabilities and motivation based upon his or her acceptance or rejection of in-role and extra-role tasks and the

subordinate's subsequent performance on assigned tasks. Subordinates who are evaluated favorably and differentiate themselves from others progress into the role-making phase. It is in this phase that the nature of the LMX relationship begins to take shape. Typically, the supervisor provides an opportunity for the subordinate to attempt a task with minimal direction and it is up to the subordinate to negotiate for resources that will facilitate performance in the given role. Finally, in the role-routinization phase, the supervisor and subordinate develop clear mutual expectations and the social exchange relationship stabilizes (Graen & Scandura, 1987). During this phase, trust becomes a foundational aspect of the relationship; the supervisor trusts that the subordinate will continue to exert extra effort, resulting in high task and contextual performance, and the subordinate trusts that he or she will be able to negotiate for resources and opportunities that best suit his or her needs (Gerstner & Day, 1997).

The quality of the LMX relationship is cultivated through this three-stage process. A high-quality LMX relationship is one in which mutual affect or liking, contribution, loyalty, and professional respect exist between the supervisor and a subordinate (Liden & Maslyn, 1998). High-LMX relationships are founded in emotional support, trust, and respect and are considered 'mutually beneficial' for both parties (Gerstner & Day, 1997). Subordinates in high-quality LMX relationships benefit from greater access to organizational resources, including increased communication, support, responsibility, and negotiating latitude (Gerstner & Day, 1997; Graen & Scandura, 1987). In exchange for these resources, a high-LMX subordinate feels a reciprocal obligation to his or her supervisor, often leading to increased performance and commitment. Conversely, lower quality LMX relationships tend to be economically-based and more closely abide by the employment contract (Gerstner & Day, 1997). Low-LMX subordinates operate strictly within their formally prescribed role and therefore the feelings of reciprocal obligation

are not as salient (Wayne, Shore, & Liden, 1997). Although they are treated fairly according to the employment contract, low-LMX subordinates are also provided fewer opportunities for role negotiation (Duchon, Green, & Taber, 1986).

Understanding work-family experiences through leader-member exchange. One of the most consistent findings in work-family research is that working adults with greater access to resources are better able to deal with stressors and demands (Crawford, LePine, & Rich, 2010). When specifically aimed at the intersection of work and family, the resources generated from high-quality LMX relationships can be used to manage and cope with competing role demands and improve performance at home (Litano et al., 2016; Major & Morganson, 2011). The following sections summarize the literature connecting LMX and work-family conflict and enrichment and further develop the conceptual linkage between these constructs.

LMX and work-family conflict. The notion of resource generation and availability has long been a topic of interest in the work-family literature. In particular, Conservation of Resources (COR) theory serves as a primary driver of work-family research (Li, Shaffer, & Bagger, 2015; Matthews & Toumbeva, 2015). COR theory posits that individuals possess a limited amount of resources, and they pursue psychological well-being by accumulating and conserving an adequate supply of valuable resources (Hobfoll, 1989, 2001). Individuals draw from this store of resources to increase or maintain high levels of subjective well-being, to generate more resources, and to make psychological adjustments to stressful situations (Li et al., 2015). COR suggests that individuals experience stress when there is a threat of a resource loss, an actual resource loss, or a lack of expected resource gains (Grandey & Cropanzano, 1999). With respect to the work-family interface, COR is particularly germane as resources are

exhausted when individuals attempt to manage and cope with competing role demands (Grandey & Cropanzano, 1999).

Given that immediate supervisors often act as the gatekeepers to organizational resources, COR theory is an appropriate framework for understanding the relationship between LMX and WIF. As previously described, supervisors provide higher-LMX subordinates with greater access to resources and opportunities that, when specifically directed toward work-family management, may be used to fulfill their work-family needs (Major & Morganson, 2011; Matthews, Bulger, & Booth, 2013). Conversely, subordinates in lower-quality LMX relationships are afforded fewer resources (e.g., support, flexibility, autonomy; Gerstner & Day, 1997; Graen & Scandura, 1987) and less latitude to negotiate a work role that is more conducive to their work-family needs (Major & Morganson, 2011). Indeed, a recent meta-analysis demonstrates that LMX and WIF share a strong negative relationship (Litano et al., 2016). In the current study, it is also proposed that LMX and WIF share a negative relationship.

Hypothesis 2: Subordinate-rated LMX will be negatively related to WIF.

LMX differs from traditional leadership theories that describe leadership from either the leader's or followers' perspectives in that it positions the dyadic relationship between supervisors and subordinates as the emphasis of the leadership process (Dansereau et al., 1975; Graen & Cashman, 1975). Rather than treating leadership as consistent across all subordinates, an important feature of LMX theory is that it centers on the unique relationships between a leader and each of his or her followers (Graen & Scandura, 1987; Sin, Nahrgang, & Morgeson, 2009). Despite this distinguishing feature, the supervisor's perspective of LMX quality is noticeably lacking from leadership literature. Even more troublesome is that when both supervisors' and subordinates' perceptions of LMX quality are assessed, meta-analyses demonstrate only a

moderate positive correlation between the two ratings (Gerstner & Day, 1997; Sin et al., 2009). Furthermore, these meta-analyses suggest that both parties' assessments of LMX quality are important and contribute meaningful variance in the prediction of employee and organizational outcomes. Since both supervisors and subordinates are key contributors to the LMX relationship, LMX quality is highest when both parties participate in the social exchange process (Maslyn & Uhl-Bien, 2001). Coupled with the fact that the leader's perspective of LMX quality is practically absent from the work-family literature (Litano et al., 2015), the aforementioned research suggests that the extant literature examining subordinate-rated LMX and work-family experiences may be incomplete.

The majority of the literature examining LMX and work-family experiences suggests that subordinates who perceive higher-quality LMX relationships receive greater access to organizational resources that can be applied to better manage the work-family interface (e.g., Major et al., 2008; Major & Morganson, 2011). However, it is the leader who typically is in the position to offer such resources, and it is theoretically the leader's actions that drive resource allocation (Gerstner & Day, 1997; Sin et al., 2009). Therefore, it seems likely that a high-LMX subordinate is afforded greater access to organizational resources when his or her supervisor also perceives the LMX relationship to be high-quality. It is hypothesized that the supervisor's perspective of LMX quality moderates the negative relationship between subordinate-rated LMX and WIF, such that the magnitude of the negative relationship is enhanced as supervisor-rated LMX increases.

To date, only one published study has directly examined the relationship between supervisor-rated LMX and WIF. In an examination of antecedents to family supportive supervisor behaviors (FSSB), Epstein et al. (2015) demonstrated a significant positive correlation

between supervisor-rated LMX and subordinate-rated WIF $r = .14, p < .05$. Interestingly, the relationship between supervisor-rated LMX and subordinate-rated FSSB was also positive and significant, indicating that supervisors were more likely to engage in family-supportive behaviors directed toward employees they rated as high-LMX. Unfortunately, WIF was not modeled as an outcome of supervisor-rated LMX, but rather both were modeled as antecedent to subordinate-rated FSSB. Given the unexpected positive relationship between supervisor-rated LMX and WIF, it is important to note two possible limitations of this study. First, the dissertation (Epstein, 2010) on which this research study was based was examined to search for discrepancies. Contrary to what is reported in the published manuscript, all of the tables in the dissertation depict negative, non-significant relationships between supervisor-rated LMX and employee WIF. Although an additional 157 subordinates (total $N = 312$) were included in the published manuscript (Epstein et al., 2015), the magnitude of the positive relationship between supervisor-rated LMX and employee-rated WIF among these 157 subordinates would have had to be approximately twice the positive effect ($r = .14$) reported in the study given the negative correlations in the initial sample (Epstein, 2010). Although it cannot be confirmed by examination of the two manuscripts, given that LMX and WIF both exhibit expected relationships with other variables of interest, including FIW and FSSB, it seems possible that the negative sign of this correlation may have been accidentally omitted. Second, although Epstein et al. (2015) labelled their variable supervisor-rated LMX, they used three items developed by Wu and Taber (2009) which tapped managerial ratings of the effectiveness of each subordinate in completing job responsibilities, the amount of trust they had in each subordinate, and the amount of responsibility delegated to each employee. While this construct is conceptually aligned with certain aspects of LMX theory, the extant literature shows no evidence that this measure was

subjected to validation tests, nor has it been published or recognized in the *Oxford Handbook of Leader-Member Exchange* as a valid measure of supervisor-rated LMX (Liden, Wu, Cao, & Wayne, 2015). In fact, the dissertation and published manuscript in question are the only two articles to cite the Wu and Taber (2009) scale. Therefore, the current study proposes that when using an established, valid measure of supervisor-rated LMX, the results will align with theory and show that supervisor-rated LMX is negatively linked to WIF.

Hypothesis 3: There will be a negative relationship between supervisor-rated LMX and WIF.

Hypothesis 4: Supervisor-rated LMX will moderate the relationship between subordinate-rated LMX and WIF, such that the magnitude of the negative relationship between subordinate-rated LMX and WIF will be stronger at higher levels of supervisor-rated LMX.

LMX and work-family enrichment. In addition to facilitating an individual's ability to cope with a variety of demands and stressors, the generation of resources in one role also has the potential to improve one's energy, performance, and quality of life in another role (Greenhaus & Powell, 2006; Marks, 1977). Whereas COR theory emphasizes that the salience of potential or actual resource loss is the driver of individuals' motivation to obtain and preserve valuable resources (Hobfoll, 2001), the job demands-resources model (JD-R; Demerouti, Bakker, Nachreiner, & Schaufeli, 2001) assumes that job resources possess motivational properties that serve to facilitate positive physical, psychological, and work outcomes through a fulfilling, positive psychological state known as engagement (Demerouti et al., 2001; Schaufeli & Bakker, 2004). COR theory is often used to explain how the JD-R model works, and together act as a relevant framework for understanding WFE. The JD-R model posits that one's work

circumstances can be classified into two general types (i.e. job demands and resources) that are differentially related to subordinate outcomes. In the JD-R model, job resources are defined as factors of the work environment that help individuals manage and cope with work demands and the associated psychological costs, stimulate personal growth and development, or facilitate goal achievement (Demerouti et al., 2001; Schaufeli & Bakker, 2004). Job resources may occur in the form of social factors, such as supervisor and coworker support; organizational elements, such as autonomy; psychological factors, including resilience and coping; and physical factors, such as money and time (Demerouti et al., 2001; Schaufeli & Bakker, 2004). When resources are plentiful, individuals are more likely to experience positive gains by capitalizing on available resources in one role (e.g., work) that can then be applied, sustained, and reinforced in another role (e.g., family; Greenhaus & Powell, 2006).

As previously described, work-family enrichment may occur through both instrumental and affective pathways (Greenhaus & Powell, 2006); and resources generated in high-quality LMX relationships may facilitate WFE through both conduits (Litano et al., 2016). In the instrumental pathway, resources gained in one role (e.g., work) are directly transferred to another role (e.g., family), improving performance and quality of life in the latter domain (Greenhaus & Powell, 2006). Greenhaus and Powell (2006) identified a particular set of resources that can facilitate WFE directly through the instrumental path; skills and perspectives (e.g., interpersonal skills, conflict management skills, perspective-taking), psychological and physical resources (e.g., self-efficacy, energy, positive emotional states), social capital (information, support), material resources (e.g., income), and flexibility (e.g., control over when and where work is completed). Supervisors provide high-LMX subordinates with greater access to all of these resources in exchange for their high performance and commitment. For example, high-LMX

subordinates are delegated greater discretion and responsibility in their work tasks (Gerstner & Day, 1997), which may enable them to develop skills and perspectives that can be directly applied in the family domain. Research suggests that high-LMX subordinates acquire more favorable performance appraisals, promotions, satisfying positions, and are more satisfied with their pay than their low-LMX counterparts, providing some evidence that material resources may also be generated through this relationship (Dulebohn et al., 2012; Graen, Wakabayashi, Graen, & Graen, 1990). Since research has demonstrated high performance in one role to increase self-efficacy and performance in other life roles (Bandura, 1997; Friedman & Greenhaus, 2000), LMX may facilitate psychological resources through positive feedback, recognition, and favorable performance evaluations. High-LMX subordinates also benefit from greater support, access to information, and more frequent communication with their supervisor (Kacmar, Witt, Zivnuska, & Gully, 2003; Matthews & Toumbeva, 2015). When this information and support is specific to work-family (i.e. information about elder or child care services, instrumental or emotional work-family support), LMX may generate social capital resources that serve to facilitate WFE.

Subordinates in higher-LMX relationships may also experience WFE via the affective pathway when resource gains derived from the supervisor-subordinate relationship result in enhanced family role performance via positive affect. This process may occur in one of two ways. Essentially, the accumulation of valuable resources at work is associated with one's positive attitudes and feelings about his or her work role (Greenhaus & Powell, 2006). First, resources generated from the LMX relationship may serve to increase job performance, creating an enhanced psychological state at work may then spill over to the family domain, promoting engagement and performance at home. Second, the abundance of resources may directly generate

positive affect at work, which then stimulate positive interactions and engagement in the family role (Greenhaus & Powell, 2006).

Ultimately, subordinates in higher-quality LMX relationships receive greater access to resources and opportunities in exchange for their high performance and to ensure future productivity. Work-family enrichment transpires when these resources are applied to stimulate personal growth and development, or facilitate performance in the family domain. A recent meta-analysis suggests that LMX and WFE share a strong positive relationship (Litano et al., 2016). This study sought to replicate findings that demonstrate a positive relationship between LMX and WFE.

Hypothesis 5: Subordinate-rated LMX will be negatively related to WFE.

WFE specifically implies that resources acquired in one domain (i.e., work) directly facilitate increased role performance in another domain (i.e., family), or indirectly do so via positive affect (Greenhaus & Powell, 2006). Just as it is predicted that subordinates at the highest levels of supervisor-rated LMX will benefit from greater access to organizational resources that can be applied to better manage and cope with competing role demands (i.e., reduced WIF), it is expected that this resource munificent condition will result in higher family role performance; either by directly applying these resources at home, or indirectly via positive affect in both roles. Given that LMX theory posits that supervisors delegate greater responsibility, opportunities and afford greater resources to those subordinates they perceive to be high-LMX (Graen & Uhl-Bien, 1995; Scandura & Schriesheim, 1994), it was expected that supervisor-rated LMX and WFE will share a strong positive relationship. Furthermore, it was expected that subordinate experiences of WFE would be most favorable when both the supervisor and subordinate perceive LMX quality to be high.

Hypothesis 6: Supervisor-rated LMX and WFE will be positively related.

Hypothesis 7: Supervisor-rated LMX will moderate the relationship between subordinate-rated LMX and WFE, such that the magnitude of the positive relationship between subordinate-rated LMX and WFE will be stronger in magnitude at higher levels of supervisor-rated LMX.

Negotiating for Optimal Work-Family Experiences

As mentioned above, individual perceptions of work-family balance refer to an individual's self-evaluation that he or she possesses adequate resources to pursue relevant work and family goals at that particular time (Major & Litano, 2014); and perceptions of work-family balance vary across life and career stages (Litano et al., 2014). This conceptualization of work-family balance is critical to understanding its relationship with idiosyncratic deals, as they can be used to reduce the psychological stressors that are produced when characteristics of the job, organization, or work environment are incongruent with one's work-family needs, values, or goals (i.e. person-job fit; Edwards & Rothbard, 1999; Kristof-Brown, Zimmerman, & Johnson, 2005). As described in the following sections, I draw from the literature surrounding social exchange theory and idiosyncratic deals to propose that through high-quality leader-member exchange relationships, specialized work arrangements can be negotiated to modify work conditions in such a way that an individual's job characteristics become more congruent with their salient work and/or family goals. Ultimately, idiosyncratic deals are hypothesized to be a missing link in the relationship between LMX and optimal work-family experiences.

Idiosyncratic deals. Over the past 15 years, human resource management practices have evolved toward less standardization and greater individualization in employment arrangements (Broschak & Davis-Blake, 2006; Rousseau, Hornung, & Kim, 2009). In response to this growing

trend, idiosyncratic deals (i-deals) have emerged in the psychological and management literatures as a means of conceptualizing and operationalizing these customized arrangements. I-deals refer to individualized employment arrangements that are mutually beneficial to the employee and employer (Rousseau, 2005). Rather than acting as implied or subjective employment conditions as are psychological contracts, i-deals are objective work features that are purposefully negotiated by an employee (Anand, Vidyarthi, Liden, & Rousseau, 2010). Although conceptually similar to job crafting, defined as “physical and cognitive changes individuals make in the task or relational boundaries of their work” (Wrzesniewski & Dutton, 2001, p. 179), i-deals differ in that they refer strictly to objective modifications to employment arrangements through employer-employee negotiation (Liao, Wayne, & Rousseau, 2014). Conversely, job crafting is often operationalized as objective *or* cognitive changes to one’s job that are made independently; oftentimes without employer authorization (Hornung, Rousseau, Glaser, Angerer, & Weigl, 2010; Wrzesniewski & Dutton, 2001).

To be formally considered an idiosyncratic deal, the specialized work arrangement must be defined by four characteristics. First, the employee must directly negotiate some aspect of one’s employment arrangement with his or her employer, although either the employee or leader may initiate the i-deal (Rousseau, 2001, 2005). In line with the norm of reciprocity (Blau, 1964; Gouldner, 1960), i-deals must also be mutually beneficial for both parties; that is, employees negotiate i-deals to satisfy a personal need and leaders agree to i-deals in reciprocation for high performance or as a means of motivating or retaining a valued employee (Rousseau, 2005; Rousseau, Ho, & Greenberg, 2006). Third, successfully negotiated i-deals offer an employee work conditions that differ from other employees in his or her workgroup (Rousseau et al., 2006). Finally, the extent to which i-deals constitute work conditions must vary across

employees. For example, the employment relationship may be limited to a single idiosyncratic feature (e.g., schedule and/or location flexibility) or be entirely idiosyncratic (Rousseau, 2005).

Negotiating idiosyncratic deals through leader-member exchange. I-deals can be negotiated in the recruitment or selection phase of the employment relationship (i.e. ex-ante) or throughout the course of an existing employment relationship (i.e. ex-post; Rousseau, 2001). Whereas ex-ante i-deals are largely based on the prospective employee's market value, an employee tends to bargain for ex-post i-deals as the social exchange relationship with his or her manager or other organizational representative develops (Rousseau et al., 2006). In the present study, ex-post i-deals are emphasized due to their emphasis on the supervisor-subordinate relationship.

As the most proximal organizational representative and the person most likely to influence whether ex-post i-deals are authorized (Hornung et al., 2010), immediate supervisors are essential to i-deal negotiation. Social exchange theory, which posits that relationships in the workplace evolve over time as individuals exchange valuable resources (Blau, 1964; Wayne et al., 1997), is an ideal framework for understanding the relational context in which ex-post i-deals are negotiated. Inherent in high-quality LMX relationships is its rule of reciprocity (Cropanzano & Mitchell, 2005); that is, a participant in a social relationship (e.g., supervisor) will reciprocate positively with the other participant (e.g., subordinate) when that person behaves in a way that improves the quality of the relationship (Cropanzano & Mitchell, 2005; Rousseau et al., 2006). As the relationship quality develops, a reciprocity norm is established (Wayne et al., 1997). Founded in mutual trust and loyalty, the reciprocity norm is characterized by a sense of obligation to reciprocate the other participant with actions and resources that go beyond the requirements of his or her role (Wayne et al., 1997). In high-quality LMX relationships,

subordinates exhibit greater task and contextual performance, and are more loyal and committed to their supervisor and organization (Dulebohn et al., 2012; Gerstner & Day, 1997). In return, high-LMX subordinates are afforded more frequent communication, greater support, individualized consideration, and negotiating latitude from their supervisors (Dienesch & Liden, 1986; Gerstner & Day, 1997; Wang, Law, Hackett, Wang, & Chen, 2005). Given that employers seldom grant i-deal requests when they are not mutually beneficial, it seems likely that supervisors would be more likely to authorize i-deals initiated by high-LMX subordinates in an effort to encourage sustained high performance and future contributions to the LMX relationship. Therefore, given the increased negotiating latitude afforded by higher quality LMX relationships, i-deals may be conceptualized as an exchange currency that is generally negotiated between an individual employee and his or her leader for mutual benefit (Rousseau et al., 2006).

The extant literature suggests that the quality of the LMX relationship affords subordinates greater opportunities to negotiate for personalized flexibility in scheduling work (Hornung, Rousseau, Weigl, Müller, & Glaser, 2014; Rosen, Slater, & Johnson, 2013) and more favorable task characteristics (Hornung et al., 2010). Furthermore, the only meta-analysis examining i-deals evidenced a strong positive relationship with LMX in both Western ($\rho = .33, k = 6, N = 1,231$) and Eastern ($\rho = .28, k = 5, N = 1,390$) cultures. Of the samples included in this meta-analysis, only three included participants from the United States. Two of those were included in Rosen et al.'s (2013) manuscript describing the development and validation of an ex-post i-deals scale. In the first study, the researchers recruited undergraduate business students and showed a positive relationship between LMX and i-deals related to job tasks and work responsibilities, financial incentives, and schedule flexibility, but did not find a significant relationship between LMX and location flexibility. Possible explanations for this finding include

the fact that the participants averaged working only 20 hours per week and were predominantly employed in retail or service industries that may require face time (Rosen et al., 2013). In the second study, conducted using a sample of full-time employees, the research team showed strong positive relationships between LMX and each form of i-deal (Rosen et al., 2013). Finally, Hornung et al. (2014) showed a positive link between LMX and task i-deals among hospital employees in the US. This study sought to further examine this relationship by replicating these findings in a sample of US, white-collar workers. It was expected that LMX and i-deals would be positively related.

Although i-deals are inherently unique and vary based on employee needs, Hornung et al. (2010) classified two general types; developmental and flexibility i-deals. Developmental i-deals refer to unique opportunities for skill acquisition and career advancement, and flexibility i-deals refer to special flexibility in work hours, schedule, or location (Hornung et al., 2010; Rousseau et al., 2006). It was proposed that both developmental and flexibility i-deals can be negotiated through high-quality LMX relationships to modify employees' work conditions to benefit work-family.

Hypothesis 8 (a-b): Subordinate-rated LMX will be positively related to (a) developmental i-deals and (b) flexibility i-deals.

Flexibility i-deals and work-family experiences. Over the past few decades, the US workforce has realized a steady increase in women's participation, leading to a considerable increase in dual-career couples. Fifty-three percent of US married families were dual-earners in 2013 (Bureau of Labor Statistics, 2013) and the 2014 labor force participation rate for working mothers and fathers was 70.1 and 92.8 percent, respectively (Bureau of Labor Statistics, 2014). To ease the burden of work-family management and to remain competitive among other family-

friendly firms, organizations are increasingly adding formal work-family benefits and family-friendly policies (e.g., childcare, eldercare, parental leave; Major, Burke, et al., 2013; Swody & Powell, 2007). Flexible work arrangements (FWA), defined as work options that allow employees control over 'where' and/or 'when' work is performed (Christensen & Staines, 1990; Hohl, 1996), have become a popular family-friendly policy offered by organizations as an alternative to the traditional work schedule (Allen et al., 2013). When offered by their employer, employees can take advantage of flexibility policies such as a compressed work schedule (i.e. work more hours per day but less days per week; Lambert, Marler, & Gueutal, 2008), telecommuting (i.e. remote work performed by using information and computer technologies, such as the Internet; Tremblay, Paquet, & Najem, 2006), reduced workloads (i.e. voluntary part-time work; Kelly & Kalev, 2006), or flextime (i.e. control over starting and stopping times each day; Christensen & Staines, 1990) to better accommodate their family role requirements.

Although research examining FWA has proliferated in the work-family literature, many studies have demonstrated extremely small or non-significant relationships with work-family outcomes. For example, the most comprehensive meta-analysis examining FWA shows small-medium negative relationships between WIF and the use of flexplace and the availability of flextime, however the 95 percent confidence intervals for the availability of flexplace and the use of flextime included zero (Allen et al., 2013). One potential explanation for this finding is that although FWA may be universally offered by an organization, the administration of FWA may be more situation-specific. Work-family scholars have argued that universal work-family policies may be ineffective due to the considerable variability in employees' family circumstances and needs (Major & Germano, 2006; Major & Lauzun, 2010). Indeed, semi-structured interviews with 45 human resource managers across 41 diverse organizations revealed

that although FWA were sometimes presented as universal across all employees, immediate supervisors were reported as having discretion over employees' access to FWA in each of the organizations that permitted their use. Kelly and Kalev (2006) summarized the management of FWA as "formalized policies that explicitly set up negotiations between managers and individual workers about access to FWA" (p. 394). Not only did the types of FWA offered vary across organizations, but their access and use were contingent on managerial discretion (Kelly & Kalev, 2006).

As a result, it is argued that flexibility i-deals better represent how FWA manifest in organizations. Rather than treating FWA as universal policies that are equally available to all employees, flexibility i-deals describe personalized work arrangements negotiated between an employee and employer to make the location of their work and/or work schedule more personally accommodating (Hornung, Rousseau, & Glaser, 2008). In contrast to more distal assessments of whether or not a particular FWA is available in the organization, the extent to which an employee is able to negotiate for flexibility i-deals acts as a more proximal assessment of whether an employee was able to negotiate for a role that aligns with his or her unique family situation.

Conceptually, flexibility i-deals should be effective at optimizing employees' work-family experiences whether or not formal FWA are available. When formal FWA policies are available, flexibility i-deals can be negotiated to ensure that the particular FWAs offered by the organization accommodate the individual employee's work-family needs. For instance, Raytheon Company, a large American defense contractor, supports two primary forms of flexible work schedules that employees can choose from; a 9/80 option, in which employees work 80 hours every two weeks but receive every other Friday off, and a second option in which employees

work 40 hours per week and receive every Friday afternoon off (Raytheon, 2015). Although Raytheon technically offers formal FWA that may be preferable to the traditional work week, it seems unlikely that these arrangements meet the specific work-family needs of each employee. In this instance, an employee may be able to negotiate a flexible work schedule that better aligns with his or her work-family situation. For example, instead of half-day Fridays, an employee might negotiate a flexibility i-deal that permits an early leave on Tuesday and Thursday afternoons so he or she can be more actively involved in coaching a youth soccer team. In the presence of formal FWAs, idiosyncratic deals may allow employees to negotiate flexible work schedules that better align with their personal lives and familial responsibilities.

When FWA are not formally available to employees, flexibility i-deals can help redesign unfavorable work conditions to be more accommodating of work and family (Matthews et al., 2013). In this context, managers are particularly important in the negotiation of flexibility i-deals. For example, Lauzun and colleagues (2010) conducted a qualitative study examining supervisors' responses to employees' requests for work-family accommodations in a large Fortune 500 company with no formal policies in place to assist with work-family balance. Although employees described its work-family culture as flexible and supportive, work-family management was dependent on the supervisors' discretion. Structured interviews with 425 supervisors revealed that the majority of the 1,150 employee work-life balance requests were highly idiosyncratic (Lauzun et al., 2010). Supervisors reported approving requests for schedule changes or time off 58 percent of the time and accommodations to amount of daily work 44 percent of the time. When work-family requests were not granted, supervisors identified having a lack of authority (33.4%), insufficient resources (12.3%), or that the request was not aligned with company policy (15.3%) as the primary reasons (Lauzun et al., 2010). While this study shows

the importance of one's immediate supervisor in negotiating custom work arrangements, the high volume of approved work-family requests also demonstrates that the opportunity for flexibility i-deal negotiation exists even when formal FWA are unavailable.

Since its initial conceptualization, specific forms of flexibility i-deals have also emerged in the literature. For example, workload-reduction i-deals refer to special arrangements that result in reduced job demands, stressors, and hours (Liao et al., 2014). Rosen and colleagues (2013) further differentiated between location (i.e. place where work is completed) and schedule flexibility. Theoretically, the employee would negotiate for the particular type of flexibility i-deal that would best accommodate his or her work and family role requirements and facilitate enhanced performance in both domains. Recently, Major et al. (2013) presented an i-deals-based model of coping with work-family conflict. The authors position i-deal negotiation as the mechanism by which employees construct personalized work arrangements in order to prevent WFC from occurring when it can be anticipated (i.e. preventative work-family coping) and to effectively manage WFC when it unexpectedly transpires (Major, Lauzun, et al., 2013).

Despite the conceptual utility that i-deals contribute to the work-family literature, only a few studies have empirically examined the relationship between flexibility i-deals and work-family conflict. For example, Hornung et al. (2008) found flexibility i-deals to mediate the negative relationship between personal initiative (e.g., proactivity) and WIF. In this sample of 887 accountants employed in the Bavarian (German) public tax administration, flexibility i-deals were also negatively related to voluntary overtime, and positively related to part-time work arrangements and telecommuting (Hornung et al., 2008). In the only other existing study to have examined this link, Hornung et al. (2011) showed flexibility i-deals to mediate the negative relationship between leader consideration and work-family conflict among German medical

doctors. Although Hornung et al. (2014) did not directly examine work-family conflict, the authors demonstrated a negative relationship between flexibility i-deals and work overload in a sample of 187 German nurses and health professionals. Furthermore, reduced workload mediated the negative relationship between flexibility i-deals and psychological work strain.

Although this relationship has been examined in two previous studies, the extant literature is limited in two ways. First, although the definition of flexibility i-deals indicates that these specialized work arrangements can include location flexibility (e.g., work at home arrangements; Rousseau, 2005), current empirical examinations have only assessed the relationships between WIF and i-deals encompassing schedule flexibility (see Hornung et al., 2008; Hornung et al., 2011). Coupled with evidence from the work-family literature that demonstrates the importance of both flextime and flexplace in reducing WIF (e.g., Allen et al., 2013), the failure for the existing empirical research to examine location flexibility when connecting i-deals to WIF implies construct deficiency. The current study contributes to the literature connecting i-deals and the work-family interface by including flexibility i-deals related to both work schedule and location.

Second, the relationship between flexibility i-deals and WIF has been examined exclusively in samples of German workers. Although culturally similar to the United States (i.e., low power distance, high individualism; Hofstede, Hofstede, & Minkov, 2010), Germany is widely considered to be a more family-friendly nation for employees (Schulte, 2014). For example, whereas the US currently offers the Federal Medical Leave Act (unpaid leave for up to 12 weeks per year) as its single federal family-friendly policy for companies with 50 or more employees, Germany implemented a program called Elterngeld which pays up to two-thirds of a family's monthly mean net income as paid parental leave for up to €1,800 per month for 14

months (OECD, 2011; Livingston, 2013). Whereas a recent Gallup survey (2014) indicated US full-time employees report working an average of 47 hours per week, Germany mandates a maximum of 8 hours worked per day with full-time employees reporting an average of 38.8 hours per week (OECD, 2011; Stolz, 2012). In addition to federal assistance for childcare (OECD, 2011), German law dictates that organizations employing more than 15 employees must guarantee part-time work for up to six months to any employees who request it (Livingston, 2013). Given the considerable differences between Germany and the US in family-friendly policy required by law, the negative relationship between flexibility i-deals and WIF may be stronger among US employees. The proposed research replicated these findings in a sample of white-collar US workers and sought to demonstrate a negative relationship between flexibility i-deals and WIF.

Hypothesis 9: Flexibility i-deals will be negatively related to WIF.

Marks's (1977) expansionist approach to the work-family interface posited that participation in multiple life roles may generate resources that increase energy, which can be directed toward involvement a second role. In this study, it is proposed that flexibility i-deals are advantageous not only for ameliorating WIF, but also for customizing work features (e.g., working hours, schedule, location; Rousseau et al., 2009) that facilitate enhanced functioning and quality of life at home (i.e., increased WFE; Greenhaus & Powell, 2006). As described in earlier sections, Greenhaus and Powell (2006) identified a variety of resources that drive the work-family enrichment process, including flexibility resources. The authors formally defined flexibility as "discretion in determining the timing, pace, and location at which role requirements are met" (p. 80). Flexibility has been recognized as a valuable work-family resource (Carlson, Grzywacz, & Kacmar, 2010; McNall et al., 2010), as it may directly enhance his or her family

role performance or may indirectly produce positive affect (e.g., engagement, energy), which, in turn, benefits the employee's interactions with his or her family (Greenhaus & Powell, 2006).

To date, only two known studies have examined the relationship between FWA and WFE, but have done so in ways that may not best conceptually represent how FWA manifest in organizations. For example, Carlson et al. (2010) found a small positive relationship between FWA and WFE, but operationalized schedule flexibility as a dichotomous variable that was coded as either *traditional* (i.e., work 40+ hours per week with little flexibility over when work begins and ends) or *flexible* (i.e., permitted to make changes in work start and end times with flexibility around a minimum set of core hours. McNall, Masuda, and Nicklin (2009) demonstrated a stronger positive relationship between FWA and WFE; however the researchers operationalized FWA as the availability of flextime schedule and/or compressed workweek rather than use of these flexibility policies. Furthermore, the samples in both of these studies were recruited from a crowdsourcing website (i.e., StudyResponse) and represented a wide variety of occupations, there is no way to determine whether this flexibility was negotiated or characteristic of the respondents' jobs.

Only one study has examined the relationship between flexibility i-deals and WFE. In a sample of Chinese parents, Tang and Hornung (2015) showed flexibility i-deals to positively relate to WFE via extrinsic motivation. The authors suggested that by negotiating job features to be more flexible, employees' motivational states are shifted as they perceive they are better able to tend to familial responsibilities. Whereas flexibility i-deals may be negotiated to help employees manage and cope with demands stemming from incompatible work and family roles (i.e., WIF), it was proposed they may also be negotiated to facilitate optimal functioning in both domains (i.e., WFE).

Hypothesis 10: Flexibility i-deals will be positively related to WFE.

Developmental i-deals and work-family outcomes. It is important to recall that perceptions of work-family balance do not necessitate an equal distribution of resources across roles, but rather that an individual possesses adequate resources to pursue salient work and family goals at that particular time (Major & Litano, 2014). Given that perceptions of work-family balance vary across life and career stages (e.g., Litano et al., 2014), it seems reasonable to posit that individuals may pursue career development as way to optimize work-family balance when that particular goal is salient. The negotiation of developmental i-deals may serve as a mechanism by which employees can create a work role that is more personally fulfilling, and therefore, advantageous for work-family experiences. Task and career i-deals are two specific forms of developmental i-deals that can be negotiated. Task i-deals refer to “arrangements that individuals negotiate to create or later their own job’s content” (Hornung et al., 2010, p. 188) to make it more personally motivating or satisfying (Hornung et al., 2014), whereas career i-deals refer to personalized career development and advancement opportunities (Rousseau, 2005).

As described previously, the work-family literature tends to diverge into scarcity and expansionist perspectives. Whereas the scarcity perspective assumes that individuals possess a finite amount of resources (e.g., time, energy; Greenhaus & Parasuraman, 1999), the expansionist perspective posits that some roles may generate resources that increase energy, which can be directly transferred to another life role (Marks, 1977). Under the lens of the expansionist perspective, involvement in career development opportunities may be a means of achieving goals related to the family role.

Recently, literature recognizing the mutual influence that work and family needs may have on one’s career development has flourished. For example, in their discussion of a work-

home sustainable career, Greenhaus and Kossek (2014) emphasize that individuals' decisions related to career development can be better understood by considering the mutual influences between one's career and personal needs. Ultimately, the authors contend that involvement in a work role that is considerate of both one's personal and career needs generates domain-specific resources (e.g., well-being, energy, positive affect) that ultimately spill over to other life roles. Similarly, Direnzo, Greenhaus and Weer (2015) recently demonstrated a positive relationship between protean career orientation (i.e., an individual's inclination to pursue subjective success in career-related decisions; Briscoe, Hall, & Frautschy DeMuth, 2006; Hall, 1976) and perceptions of work-family balance. More specifically, individuals who possessed a protean career orientation were more likely to engage in career planning activities related to the accumulation of social and psychological resources, which resulted in greater work-life balance. Finally, in their 'whole-life' approach to career development, Litano and Major (2016) recognize that employees require opportunities for both professional and personal development, and suggest that employees experience the most optimal work-family outcomes and are less likely to seek inter-organizational mobility when their whole-life needs are attended to. The current research aimed to build upon the recent literature highlighting the positive influence career development can have on the work-family interface by examining the relationship between developmental i-deals and WFE.

Again drawing from the expansionist perspective, career and task i-deals afford employees the opportunity to augment their work role beyond the limitations of his or her regular job scope and expand upon their knowledge, skills, and perspectives within that role (Hornung et al., 2008; Hornung et al., 2014). Career i-deals are negotiated specifically for enrichment of the work role; however the permeability of the work-family interface enables the resources gained

from the enriched work role to transfer to the family domain (Greenhaus & Powell, 2006). For example, employees who negotiate for career development opportunities likely gain skills (e.g., coping, multitasking, and conflict management skills) and perspectives (e.g., empathy, perspective-taking) from their amplified work role that can directly be applied to enhance performance at home.

In addition, the negotiation of job characteristics via task i-deals is aligned with the expansionist perspective (Hornung et al., 2010), and may impact WFE indirectly through positive affect. Founded in job characteristics theory (Hackman & Oldham, 1976), five core job characteristics impact work motivation, job satisfaction, and performance (i.e. quality and quantity of work) through three psychological states; experienced meaningfulness of the work, experienced responsibility for work outcomes, and knowledge of work results (Hackman & Oldham, 1980). Hackman and Oldham (1976; 1980) identified these core job characteristics to be *skill variety* (i.e. extent to which a job requires various activities, requiring the use of different skills and abilities), *task identity* (i.e. extent to which the job requires employees to identify with and complete a task with a visible outcome), *task significance* (i.e. extent to which the job or task has an impact on the lives or work of others), *autonomy* (i.e. extent to which the job or task offers the employee independence and discretion over the work), and *feedback* (i.e. extent to which the employee clear, detailed, and actionable information about the effectiveness of his or her job performance). When employees successfully negotiate for task i-deals, they likely experience positive psychological states associated with the augmented job characteristic, (e.g., energy, positive affect; Humphrey et al., 2007; Pierce, Jussila, & Cummings, 2009), that may spill over to the family domain.

To date, only one empirical study has included both developmental i-deals and WFE in the same study. Tang and Hornung (2015) found support for a model in which flexibility i-deals were indirectly related to WFE via extrinsic motivation, and developmental i-deals were indirectly related to work engagement via intrinsic motivation. Although the authors did not indicate statistical significance in this article, an inspection of the study's correlation matrix revealed the existence of a statistically significant positive relationship between developmental i-deals and WFE, $r = .20$, $n = 179$, $p = .007$ (see Tang & Hornung, 2015, p. 947). Relatedly, Baral and Bhargava (2011) found a set of the five job characteristics to positively relate to WFE, even after controlling for the effects of family, supervisor and coworker support, work family balance policies, and work-family culture.

In sum, developmental i-deals can be negotiated to modify one's work conditions to be more congruent with their salient work and/or family goals. Whether via the acquisition of resources in one's amplified work role (career i-deals), or via enhanced psychological states from modified job content or characteristics (task i-deals), employees who successfully negotiate developmental i-deals should perform better in their family roles. In this study, it was proposed that developmental i-deals would be positively related to WFE.

Hypothesis 11: Developmental i-deals will be positively related to WFE.

To date, the two empirical studies that have examined the relationship between developmental i-deals and WIF have provided conflicting results. Hornung et al. (2008) showed developmental i-deals to positively relate to work-family conflict ($\beta = .15$, $p < .01$) when holding the effects of flexibility i-deals constant. Hornung et al. (2011) also examined this link, but did not find a statistically significant relationship between developmental i-deals and WIF in two independent samples of German physicians. Relatedly, task and career i-deals were not

significantly related to work overload or psychological strain (Hornung et al., 2014). Although these two constructs are not directly representative of work-family conflict, they do serve as key work-related demands that typically share strong positive relationships with WIF (e.g., Bolino & Turnley, 2005; Clayton, Thomas, Singh, & Winkel, 2015; Grandey & Cropanzano, 1999).

In the proposed research, no relationship is expected between developmental i-deals and WIF. Although developmental i-deals involve the negotiation of special assignments, additional responsibility or training to develop career-related competencies, they inherently strengthen an employee's work role involvement (Hornung et al., 2014; Rousseau, 2009). Successfully negotiated developmental i-deals inspire and reward subordinates' continued and future high performance and commitment (Hornung et al., 2008). Hornung and colleagues (2008) suggested that developmental i-deals likely shape the employees' performance expectations and result in extra hours invested in the job, resulting in competing work and family demands. While this is certainly a plausible explanation, this research proposes that an employee would likely only negotiate for a developmental i-deal if it aligned with his or her salient goals at that time. Since work-family balance perceptions change over life and career stages, at any given point an individual may conceptualize 'balance' to involve prioritizing the work role (Litano et al., 2014). For example, an individual seeking career advancement may willingly invest additional time and effort in one's work role in order to increase his or her family's economic security. Given that developmental i-deals are intentionally negotiated by the employee, it seems likely that individuals who successfully negotiate them are doing so with the understanding that balance may temporarily shift toward the work role. This is in contrast to those employees who are unwillingly burdened with additional responsibility in the work role.

I-deals: A missing link in the relationship between LMX and work-family experiences.

Although it is well established that participation in a high-quality LMX relationship is advantageous for work-family experiences (Litano et al., 2016), the mechanisms through which LMX influences WIF and WFE remain largely understudied. To date, very few studies have empirically examined potential mediators of these relationships. For example, in their foundational article, Bernas and Major (2000) showed LMX to be negatively related to WIF through reduced job stress. Similarly, Culbertson, Huffman, and Alden-Anderson (2009) showed hindrance-related stress, or stressful demands that are perceived to impede one's ability to achieve goals (LePine, LePine, & Jackson, 2004), mediated the negative relationship between the affect and loyalty dimensions of LMX and WIF. Major and colleagues (2008) demonstrated that LMX not only shared a negative direct relationship with WIF, but that LMX was also related to lower WIF via increased coworker support. More recently and using multi-wave data, Litano and Major (2015) provided evidence that LMX is indirectly related to WIF via family-supportive supervisor behaviors (FSSB), and that these effects extend to work-family balance satisfaction at a later time point. Finally, Hill and colleagues (2016) demonstrated LMX to negatively relate to WIF through fewer psychological contract breaches, or employees' unmet expectations about their employment agreement.

Empirical research examining mediators of the LMX – WFE relationship is even more uncommon. Tummers and colleagues (2014; 2013) showed meaningfulness of work, a psychological resource, to mediate the relationship between LMX and WFE. However, both of these studies utilized the same sample, meaning that only one empirical study has provided unique evidence of LMX indirect effects on WFE. Interestingly, two other studies have examined mediators of this relationship to no avail. For example, Culbertson et al. (2009) did not

find that challenge-related stress (i.e., work stress associated with challenging job demands that produce feelings of achievement and fulfillment; LePine et al., 2004) mediated the relationship between LMX and WFE. Furthermore, Litano and Major (under review) showed a direct positive relationship between FSSB and WFE; however, when LMX was added to the model, the direct relationship between FSSB and WFE became non-significant and the indirect relationship from LMX to WFE via FSSB was also non-significant, $\beta = -.047, p = .749$.

In sum, the extant literature has considered only a few of the potential mechanisms by which LMX impacts work-family experiences. The present research makes a contribution to the work-family literature in that it seeks to examine idiosyncratic deals as a driver of this relationship. Theoretically, high-quality LMX relationships afford subordinates greater negotiating latitude (Dienesch & Liden, 1986) through which they can barter for developmental and/or flexibility i-deals relevant to their salient work and family goals or needs. Although this relationship has not yet been empirically examined, Litano and Major's (under review) findings suggest supervisors may be more likely to engage in behaviors that are considered to be supportive of subordinates' work-family needs when in high-LMX relationships (Matthews et al., 2013). In order to maintain the quality of high-LMX relationships and to encourage sustained performance, supervisors may be more likely to authorize specialized work arrangements designed to better suit the work-family needs of high-LMX subordinates. For example, flexibility i-deals may be negotiated in high-quality LMX relationships to prevent WIF from occurring, or to address it when it arises (Major, Lauzun, et al., 2013). Additionally, high-LMX subordinates may be better able to negotiate schedule or location i-deals that serve as flexibility resources that facilitate performance in one's family role directly, or via enhanced positive affect. Finally, high-LMX subordinates may negotiate developmental i-deals through which they develop skills,

perspectives, and other resources that directly or indirectly enhance participation at home. As depicted in Figure 1, it was expected that i-deals mediate the relationship between LMX and favorable work-family experiences.

Hypothesis 12: Flexibility i-deals will partially mediate the negative relationship between LMX and WIF, such that high-LMX subordinates will more successfully negotiate flexibility i-deals that serve to ameliorate WIF.

Hypothesis 13: Flexibility i-deals will partially mediate the positive relationship between LMX and WFE, such that high-LMX subordinates will more successfully negotiate flexibility i-deals that facilitate WFE.

Hypothesis 14: Developmental i-deals will partially mediate the positive relationship between LMX and WFE, such that high-LMX subordinates will more successfully negotiate developmental i-deals that facilitate WFE.

The Leader as a Negotiating Partner: Embracing the Leader's Perspective of LMX

Although i-deals can be negotiated and authorized at any organizational level (Major & Litano, 2015), an individual's immediate supervisor most frequently represents his or her negotiating partner (Hornung et al., 2009; Rousseau, 2004). Inherent in the definition of i-deals is the notion that such specialized work arrangements not only require employer authorization, but also are mutually beneficial for both parties (Rousseau, 2004; 2005). As such, it seems unlikely that a supervisor would be willing to authorize i-deal requests when he or she does not perceive potential benefits from the proposed arrangement. In her seminal work on the topic, Rousseau (2001; 2005) suggested that supervisors may be more likely to authorize i-deals in order to retain capable and skilled employees, as a way to encourage sustained or improved performance, or as a way to facilitate work-family balance for valued employees.

However, to date, only one study has evaluated i-deals from a managerial perspective. In a sample of 263 supervisors employed in the German tax administration, Hornung et al. (2009) empirically tested a model examining the supervisors' evaluations of i-deal authorization and the anticipated consequences associated with granting different types of i-deals. In addition to authorizing both flexibility and developmental i-deals as a reward for employee initiative, supervisors anticipated increased performance and motivation in exchange for granting developmental i-deals, and expected subordinates' work-family balance to be enhanced via flexibility i-deals. Interestingly, supervisors also granted workload reduction i-deals as a way of reciprocating unfulfilled organizational obligations (e.g., psychological contract violations) and did not anticipate receiving any benefits (i.e., performance, motivation, work-family balance) from such an agreement (Hornung et al., 2009). Such findings align well with LMX theory, particularly from the supervisor's perspective. Given the reciprocity norm inherent in LMX, supervisors may feel obligated to reciprocate the contributions of high-LMX subordinates by negotiating and authorizing i-deals that keep these employees motivated, and to reward them for their high task and contextual performance. In addition, negotiating an i-deal that is initiated by a high-LMX subordinate may communicate the value and importance placed on that LMX relationship, further cultivating LMX quality (e.g., Dienesch & Liden, 1986; Hornung et al., 2010; Rousseau et al., 2006). LMX researchers have long argued that the supervisor's perspective of LMX quality is more relevant when evaluating supervisory actions (Gerstner & Day, 1997; Scandura & Schriesheim, 1994); emphasizing the importance of supervisor-rated LMX in understanding i-deal negotiation. It was anticipated that supervisor-rated LMX quality positively relates to the extent to which i-deals are successfully negotiated.

Hypothesis 15 (a-b): Supervisor-rated LMX quality will be positively related to (a) developmental i-deals and (b) flexibility i-deals.

Theoretically, LMX describes the quality of the reciprocal exchange relationship between a supervisor and each of his or her subordinates (Graen & Uhl-Bien, 1995). These relationships vary in quality; low-quality LMX relationships are more strictly based on the employment contract and are transactional or economic in nature, and high-quality LMX relationships are founded in mutual affect, loyalty, professional respect, and contribution, and are characterized by the exchange of valuable organizational resources (Liden & Maslyn, 1998; Liden, Sparrowe, & Wayne, 1997). Empirically, both supervisor and subordinate perceptions of LMX quality are important and contribute unique information to the prediction of important work-related outcomes (Gerstner & Day, 1997; Sin et al., 2009). Despite this, the leadership literature is overflowing with research examining only one member's perception of LMX quality. This conceptual and empirical discrepancy is problematic because measurement of only one member's perspective infers that leaders and followers perceive LMX quality similarly. This is particularly troublesome given the meta-analytic evidence suggesting moderate correlations between the two members' LMX ratings ($r = .32, \rho = .37$; Sin et al., 2009). Scholars have argued that describing LMX theory through a relational lens but then assessing only one dyad member's perspective of the relationship provides an inadequate representation of the exchange process (Krasikova & LeBreton, 2012; Matta, Scott, Koopman, & Conlon, 2015).

Therefore, the present research aimed to contribute to this growing body of literature by examining supervisor-rated LMX as a moderator of the relationship between subordinate-rated LMX and i-deals. Furthermore, this study sought to examine how the effects of this interaction extend to subordinates' work-family experiences. As depicted in Figure 2, supervisor-rated LMX

was expected to enhance the positive relationship with i-deals, such that subordinates who perceive high-LMX will report having successfully negotiated i-deals to a greater extent when their supervisors perceive LMX quality to be higher. Indeed, the few studies that have examined both supervisor and subordinate-rated LMX suggest that the most favorable outcomes are realized when both parties perceive LMX favorably (e.g., Cogliser et al., 2009; Matta et al., 2015). This is because in high LMX relationships, both parties have established the norm of reciprocity and exchange resources based on the other's contributions (Cogliser et al., 2009; van Gils, van Quaquebeke, & van Knippenberg, 2010; Zhou & Schriesheim, 2010). Given the increased support and more frequent communication experienced by higher-LMX subordinates, they may be more likely to approach their supervisor about negotiating a specialized work arrangement in exchange for his or her work-related contributions. The equally-high LMX supervisor may then be more likely reciprocate by authorizing this request or bartering for an i-deal that is more mutually beneficial. However when a subordinate perceives high-LMX and the supervisor perceives LMX less favorably, the supervisor likely does not sense the same reciprocal obligation as he or she might with a subordinate perceived to be higher-LMX. As a result, the subordinate may not be afforded as much negotiating latitude to successfully barter for i-deals.

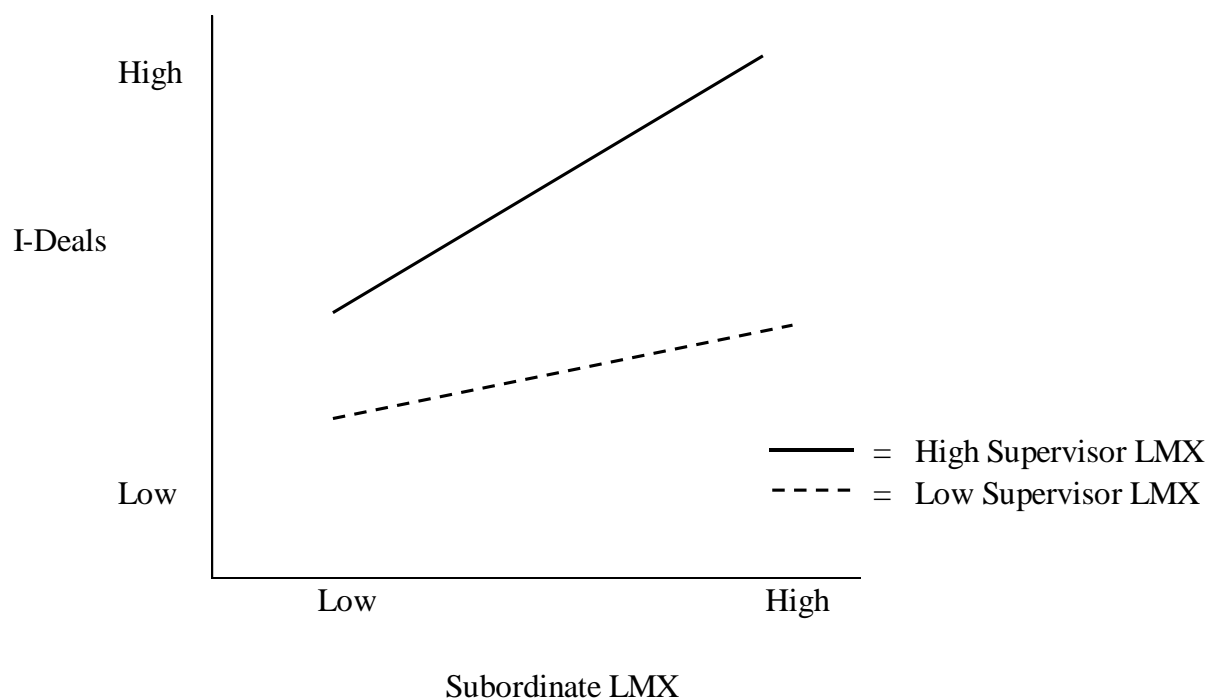

Figure 3. The expected interaction effect between supervisor-rated LMX and subordinate rated LMX on i-deals.

When both the supervisor and subordinate perceive LMX quality to be lower, they both perceive their relationship to be more well-defined by the employment contract (Cogliser et al., 2009). As a result, neither party is expected to contribute significant investments in the relationship above and beyond those required by formal job roles. Subordinates are then likely less apt to initiate the negotiation of an i-deal, and in the rare cases where he or she does barter for an i-deal, the supervisor may be less likely to consider authorizing such an arrangement. When a subordinate perceives low-LMX, but the supervisor perceives higher LMX, the subordinate may perceive that his or her contributions to the LMX relationship are not being reciprocated. Conversely, this supervisor may perceive the subordinate to be contributing to the social exchange process but may not realize that an uneven exchange of resources exists. In this case, the supervisor may expect continued contributions from the subordinate, further

influencing the subordinate's perception of an imbalanced exchange. Alternatively, this supervisor may be reciprocating the subordinate's contributions to the LMX relationship with resources the employee perceives to be irrelevant or less valuable. For example, the supervisor may provide this subordinate with task-related resources (i.e., greater responsibility) when the subordinate values flexibility resources. In either circumstance, the subordinate may be less likely to initiate i-deals even through the supervisor (who perceives higher-LMX) may authorize such arrangements.

In sum, it was proposed that supervisor-rated LMX would moderate the relationship between subordinate-rated LMX and i-deals.

Hypothesis 16 (a-b): Supervisor-rated LMX will moderate the positive relationship between subordinate-rated LMX and (a) developmental i-deals, and (b) flexibility i-deals, such that i-deals will be negotiated to a greater extent when both supervisor and subordinate perceive higher LMX.

The final aim of the current research study was to examine if the proposed mediated effects from subordinate-rated LMX to work-family experiences via i-deals are dependent on the level of supervisor-rated LMX. Given that i-deals are positively linked to subordinate-rated LMX (Liao et al., 2014) and that it is the supervisor who typically authorizes such arrangements (Hornung et al., 2009), it was proposed that not only are high-LMX subordinates more likely to experience favorable work-family outcomes by negotiating for flexibility and/or developmental i-deals, but these mediated effects were also expected to become stronger as supervisor-rated LMX increases.

Hypotheses 17 (a-b): Supervisor-rated LMX will positively moderate the strength of the mediated relationship between subordinate-rated LMX and WFE via (a) developmental and (b) flexibility i-deals, such that the path will be stronger at high rather than low levels of supervisor-rated LMX.

Hypotheses 17 (c): Supervisor-rated LMX will positively moderate the strength of the mediated relationship between subordinate-rated LMX and WIF via (c) flexibility i-deals, such that the path will be stronger at high rather than low levels of supervisor-rated LMX.

Exploring the effects of LMX congruence. Using role (Kahn et al., 1964) and social exchange (Blau, 1964) theories as their primary bases, LMX scholars have begun to argue that the theoretical rationale underlying LMX theory infers that leaders and followers are in high agreement regarding the quality of their exchange relationships (Cogliser et al., 2009; Markham, Yammarino, Murry, & Palanski, 2010; Zhou & Schriesheim, 2009, 2010). As a result, LMX researchers have started to explore the implications of LMX agreement (congruence), or the extent to which the supervisor and subordinate agree on the quality of their unique LMX relationship (Cogliser et al., 2009; Gerstner & Day, 1997; Zhou & Schriesheim, 2009).

These scholars contend that when LMX agreement is high, both the supervisor and subordinate are less likely to experience unmet expectations regarding the social exchange process (Matta et al., 2015; Zhou & Schriesheim, 2009). In this sense, LMX agreement reflects the descriptions of LMX theory most often used to explain the advantageous outcomes associated with high-LMX. However, when the mutual role expectations between a supervisor and subordinate are misaligned or misinterpreted, the two parties may differ in their perceptions of LMX quality (Matta et al., 2015). As a result of LMX disagreement, the dyad member who overestimates the quality of the relationship is likely to experience discrepancies in social

exchange expectations (Cogliser et al., 2009; Matta et al., 2015). As a result, the experiences and outcomes resulting from the LMX relationship likely vary based on which member rates LMX quality as higher, and to what extent the two differ in perceptions of LMX quality.

The extant research examining LMX congruence or agreement provides conflicting evidence of its effects. For example, Cogliser et al. (2009) showed job performance, organizational commitment, and job satisfaction to be higher when supervisor and subordinate perceptions of LMX were congruent and reported as high-quality. However, when leader-member perceptions of LMX were incongruent, relationships between LMX and outcomes varied based on which party evaluated LMX quality more favorably. In these cases, affective outcomes (i.e., job satisfaction and organizational commitment) were higher when the subordinate rated LMX more favorably, and job performance was higher when the supervisor rated LMX more favorably (Cogliser et al., 2009). Matta et al. (2015) extended these findings by demonstrating supervisor-rated organizational citizenship behaviors (OCB) to be highest when LMX congruence was also high. However, employee engagement was highest when supervisors and subordinates' ratings of LMX were congruent, regardless of the level of LMX quality.

The argument could be made that when LMX incongruence is high, unmet social exchange expectations exist that serve to expend resources, generate stress and psychological strain, and impede the exchange of resources inherent in LMX relationships. Conversely and regardless of the overall of the LMX relationship, when congruence is high, both parties achieve a mutual understanding of their working relationship; whether this entails meeting their economically-based needs (i.e., low-LMX) or through reciprocation of the resources and contributions that each party expects to receive (i.e., high-LMX). Given the importance of LMX quality in facilitating optimal work-family experiences, and also the social exchange process in

negotiating i-deals, the proposed study seeks to make a major contribution to the leadership and work-family literatures by examining the impact of LMX congruence on i-deals, WIF, and WFE through an exploratory lens.

Research Question 1: How do developmental i-deals, flexibility i-deals, and work-family experiences vary at different levels of LMX agreement?

CHAPTER II

METHOD

Participants and Procedures

To test the model hypotheses, data were collected via web-based surveys from supervisors and subordinates in a large government organization located in the southeastern US (Litano, McGowan, & Rogers, 2016, ref: TPSAS Report 26079). According to the most recent available data, this organization employs 1,798 civil service employees. The majority of the 1,798 person civil servant workforce is male (71.6%), with a median age of 51, and are employed as scientists and engineers (65.5%) and are highly educated (55% possess a Master's or Doctorate degree).

Prior to data collection, a file containing civil servant employee records was obtained from Internal Records. This file provided the contact information for all civil servant employees, their direct supervisor, and identified the branch to which they are assigned. To recruit the study sample, an e-mail was sent from the researcher's organization-specific e-mail address to the managers of 59 branches. Branch managers at this organization are generally responsible for employees' annual performance evaluations, rewards and recognition, promotion recommendations, and are responsible for authorizing benefit or policy use requests. Of the 59 e-mails sent to branch managers, 27 (45.8%) responded and agreed to meet with the researcher. The purpose of this e-mail was to schedule a personal meeting with branch managers to discuss participation in the study. In these meetings, managers were informed (a) that the data collection is for academic research purposes, (b) their potential participation is completely voluntary, and (c) that survey responses will be confidential and only disseminated in a summative, not evaluative form. To maintain employee confidentiality, branch managers were informed that

supervisor-version of the survey would include evaluations for a random sample of their employees, not to exceed 50% of the branch employees.

Branch managers were also informed that they were not permitted to encourage their subordinates' participation in the employee-version of the survey, per direct instructions from the organization's Institutional Review Board. However, the researcher was permitted to present the opportunity to participate in this study at branch meetings, and was invited to do so by eleven branch managers. The purpose of these presentations was for the researcher to introduce himself, the field of Industrial-Organizational Psychology, the current research study, and to answer any questions that potential participants may have had related to their involvement. Non-managerial civil servant employees were sent an e-mail invitation to the web-based subordinate survey in August 2016. Subordinates who did not immediately complete the survey received a maximum of two reminder e-mails time-separated by one week. Of 1,029 e-mail invitations to complete the subordinate survey, 199 employees responded (19.3% response rate). Two questions intended to assess careless responding were included in the survey to help ensure data quality (Meade & Craig, 2012). Respondents who did not pass these 'attention checks' were excluded from data analyses. A sample item is, "For data quality purposes, please select Disagree." Of the 199 respondents, seven failed attention checks. The final sample of 192 civil servant employees were nested within 44 different branches. The majority of the sample was male (71.4%) with a median age of 49 years ($M = 46.6$, $SD = 12.0$), which is comparable to the publicly available data on the population of civil servant workforce showing a largely male workforce (71.6%) with a median age of 51 years. The respondents were highly educated (72% earned a Master's degree or Ph.D.), which was a notably higher figure than that of the population (55%). Employees reported working an average of 42.7 hours per week ($SD = 4.5$), had reported to the same immediate

supervisor for an average of 3.4 years ($SD = 3.1$), and had been employed at the organization for an average of 15.4 years ($SD = 11.7$). In addition, 69.6 percent of the sample was married or cohabitating, and 66.7 percent of respondents had at least one child.

After the subordinates from a particular branch completed the subordinate survey, the manager was sent the supervisor-survey. To ensure managers were not overburdened with completing LMX measures for all employees under their span of control, a purposeful random sampling method was used to ensure that managers only completed surveys for those subordinates who participated, not to exceed 50% of his or her subordinates. Of the 27 branch managers who met with the researcher, one declined to participate in the supervisor survey, two branch managers who had agreed to participate did not have any direct-reporting employees complete the employee-version of the survey, and one final branch manager did not complete the supervisor-survey after multiple reminder messages. A final sample of 23 branch managers completed the supervisor-version of the survey (supervisor survey $n = 148$) and were included in data analyses. The branch manager sample was predominantly male (91.3%), with an average span of control of 26.7 employees ($SD = 8.3$), and reported working an average of 48.8 hours per week ($SD = 5.5$). The final sample included 133 unique, matched supervisor-subordinate dyads.

Measures

Subordinates and supervisors each completed a unique web-based survey. Means, standard deviations, and intercorrelations between the study variables are presented in Table 1.

Subordinate survey. Subordinates responded to measures of WIF, WFE, i-deals, LMX and were asked to report demographic information that were considered for use as statistical controls. Consistent with recommendations in the literature to reduce common method bias (Podsakoff et al., 2003; Podsakoff, MacKenzie, & Podsakoff, 2012), the criterion variable (WIF,

WFE) measures were positioned first in the survey, followed by the proposed mediating variable (i-deals) measure, and finally, the predictor variable (LMX) measure. These measures are described in detail below.

Work interference with family. WIF was measured using a five-item scale developed by Netemeyer et al. (1996). This scale is among the most frequently used and psychometrically sound assessments of WIF (e.g., Wayne, Casper, Matthews, & Allen, 2013; Hornung et al., 2008). Participants responded to items such as, “the demands of my work interfere with my home and family life,” on a 7-point Likert-type scale ranging from 1 (*strongly disagree*) to 7 (*strongly agree*). Coefficient alpha reliability estimates for the WIF scale were reported as .88 in the original study and range from .87 - .93 in recent published work (e.g., Carlson, Ferguson, Hunter, & Whitten, 2012; Hammer, Kossek, Yragui, Bodner, & Hanson, 2009; Netemeyer et al., 1996). Coefficient alpha in the current study was .94. The complete measure of WIF is presented in Appendix A.

Work-to-family enrichment. WFE was measured using a 3-item measure validated by Kacmar, Crawford, Carlson, Ferguson, and Whitten (2014). This is a parsimonious version of Carlson et al.'s (2006) 9-item multi-dimensional WFE scale. The short-form WFE scale uses a single item to capture each of the three WFE dimensions; affect, capital, and development. Items were prompted by, “My involvement in my work...” and a sample item is, “...helps me feel personally fulfilled and this helps me be a better family member.” Respondents indicated their extent of agreement with each statement using a 7-point Likert-type scale ranging from 1 (*strongly disagree*) to 7 (*strongly agree*). Kacmar et al. reported coefficient alpha reliability to be .84, and McNall, Scott, and Nicklin (2015) reported a reliability estimate of .78. The coefficient

alpha reliability estimate for WFE in the current study is .85. The complete measure of WFE is presented in Appendix B.

Idiosyncratic deals. I-deals were measured using 15 items adapted from two existing scales to more broadly assess the construct (Hornung et al., 2014; Rosen et al., 2013; Rousseau & Kim, 2006). Items were prompted by, “To what extent have you asked for and successfully negotiated for the following personalized conditions in your current job?” Participants responded to i-deals items using a 5-point Likert-type scale that is anchored by 1 (*e.g. not at all*) and 5 (*e.g. to a great extent*). First, six items from Hornung et al.’s (2014) 9-item measure of task, career, and schedule flexibility i-deals were included. One schedule flexibility item (i.e., *a work schedule suited to me personally*), and one career item (i.e., *ways to secure my professional development*) were excluded due to redundancy with other items. Two items intended to assess task i-deals were combined into one item (i.e., *job tasks that fit my personal strengths, talents, and interests*). Hornung et al. (2014) reported a coefficient alpha reliability estimates of .80, .88, and .78 for the task, career, and schedule flexibility scales, respectively.

In addition, 8 items were adapted from Rosen et al.’s (2013) 16-item ex-post i-deals scale. Two schedule flexibility and two location flexibility items were adapted to better align with the item prompt and to eliminate double-barreled wording. For example, the item worded, “Because of my individual needs, I have negotiated a unique arrangement with my supervisor that allows me to complete a portion of my work outside the office,” was adapted to read, “The ability to complete a portion of my work outside of the office.” In addition, three task and work responsibilities items were adapted from Rosen et al.’s (2013) to provide more conceptual breadth to the current study’s task and career i-deals scales. Finally, one item representing location flexibility was developed for this research study because Rosen et al.’s measure

included only two location flexibility items, which would lead to model identification issues when using latent variable modeling (Schumacker & Lomax, 2004). In sum, the 15-item scale used in the survey was comprised of 4 schedule flexibility, 3 location flexibility, 4 task, and 4 career development items and is presented in Appendix C.

The psychometric properties of this scale were investigated prior to conducting data analyses. First, confirmatory factor analysis was conducted to examine the latent structure of the i-deals construct using Mplus 7.4 (Muthen & Muthen, 2015). As depicted in Table 1, the goodness-of-fit for the expected 4-factor model was compared to each alternative model: a 1-factor model in which all items loaded onto the same higher-order factor, a 2-factor model in which all developmental i-deals items (task and career) loaded onto one factor, and the flexibility items (schedule and location) loaded onto a second factor, a 3-factor model (A) in which developmental i-deals items loaded onto a single factor, schedule flexibility items loaded onto a second factor, and location flexibility items loaded onto a third factor, and a 3-factor model (B) in which flexibility i-deals items loaded onto a single factor, task i-deals items loaded onto a second factor, and career development items loaded onto a third factor.

As depicted in Table 1, the expected 4-factor model fit the data better than the alternative models, $\chi^2(84) = 327.82$, RMSEA = .12, CFI = .89, SRMR = .14, however, the model goodness-of-fit statistics were less than desirable. As a result, factor cross-loadings and model modification indices were examined for potentially problematic items. An examination of the standardized factor loadings revealed two potentially problematic items. The standardized factor loading of task i-deals item 1 (i.e., flexibility in how I complete my job tasks) was extremely small ($\lambda = .36$) and reported a standard error that was nearly twice as large as any other item in the i-deals scale. Upon re-examination, this item's phrasing was determined to be problematic as it conceptually

shares similarities to the flexibility i-deals items. A more appropriate phrasing in future research studies may include an emphasis on autonomy or discretion, which appear to be the underlying purpose for this particular item. Unsurprisingly, the modification indices suggested that the model fit would improve by specifying this item to load onto the schedule and location flexibility i-deals factors. This item was flagged for future analyses.

Second, although the standardized factor loading for career development i-deals item 3 (i.e., opportunities for training or education related to my professional development) was moderate ($\lambda = .65$), model modification indices suggested this item cross-loads onto the task i-deals factor, and that the covariances between this item's error term and the error terms of all task i-deal items were substantial. As a result, this item was also flagged for future analyses.

Given that the four-factor structure emerged as the best fit to the data, internal consistency reliability estimates were calculated for the full 15-item i-deals scale, and each of the sub-scales with a watchful eye on the performance of the two flagged items. The coefficient alpha estimates for each of the four dimensions were acceptable; task $\alpha = .78$, career development $\alpha = .80$, schedule flexibility $\alpha = .90$, and location flexibility $\alpha = .95$. With respect to the task i-deals scale, an examination of the item-total statistics revealed that our flagged item was particularly problematic, as it showed weak correlations with the other 3 task i-deals items. Removal of this item resulted in a coefficient alpha reliability estimate of .85. The removal of the flagged career development i-deals item did not significantly alter the internal consistency reliability of its respective sub-scale ($\alpha = .79$).

As a result of these analyses, a confirmatory factor analysis was conducted for a revised 4-factor model which did not include the two problematic items (see Table 2). The revised 4-factor model fit the data well, $\chi^2(59) = 112.80, p < .001, RMSEA = .07, CFI = .97, SRMR = .04,$

and the chi-square difference between the originally expected 4-factor model and the revised 4-factor model, $\Delta\chi^2(25) = 215.02$, exceeded the critical value for 25 degrees of freedom, $\chi^2_{crit}(25) = 37.65$. The final 13-item scale that was used in this study was comprised of 3 task ($\alpha = .85$), 3 career development ($\alpha = .79$), 3 location flexibility ($\alpha = .90$), and 4 schedule flexibility ($\alpha = .95$) i-deals items.

In addition, one optional, open-ended question was included in the survey to understand employees' unsuccessful experiences negotiating for idiosyncratic deals. Specifically, employees were asked, "Have you ever attempted to negotiate for a personalized or unique (a) career development opportunity, or (b) accommodation for improved work-family balance, but were unsuccessful? If so, please describe your situation." In total, 74 employees responded to this question in some way.

Table 1

Comparison of Model Fit for Idiosyncratic Deals Scale

	χ^2	<i>df</i>	CFI	RMSEA	SRMR	$\Delta\chi^2$	Δdf
Expected 4-Factor Model	327.82	84	.89	.12	.14		
1-Factor Model	965.08	90	.62	.23	.16	637.26*	6
2-Factor Model	684.44	89	.74	.19	.14	356.62*	5
3-Factor Model A	391.24	87	.87	.14	.13	63.42*	3
3-Factor Model B	623.38	87	.77	.18	.15	295.56*	3
Revised 4-Factor Model	112.80	59	.97	.07	.04	215.02*	25

Note. The goodness-of-fit for the expected 4-factor model was compared to each alternative model. * $p < .001$

Leader-member exchange. Leader-Member Exchange (LMX) was assessed using Graen and Uhl-Bien's (1995) seven-item LMX-7 scale. A sample item is, "How would you characterize your working relationship with your leader?" The 5-point Likert-type response scale for this measure is anchored by 1 (*e.g. extremely ineffective*) and 5 (*e.g. extremely effective*), though the anchors vary by item. This scale is the most robust and frequently used instrument for assessing LMX quality (Gerstner & Day, 1997; Graen & Uhl-Bien, 1995). It is also a psychometrically sound instrument, as Graen and Uhl-Bien (1995) reported coefficient alpha reliability estimates ranging from .80-.90 on the LMX-7. Coefficient alpha reliability for the LMX-7 in this study is .94. The complete measure is provided in Appendix D.

Demographic variables. Participants were asked to report a number of demographic variables that were considered as potential control variables. This descriptive information includes relationship status, number of children living at home, time reporting to current supervisor (in years), time employed at the current organization (in years), and average hours worked per week, as these factors have been empirically linked to one or more of the constructs of interest (Bernerth, Armenakis, Feild, Giles, & Walker, 2007; Coglisier et al., 2009; Ford, Heinen, & Langkamer, 2007; Frone et al., 1997; Hornung et al., 2008). Scholars have recently emphasized the importance of providing both conceptual and empirical justification when considering the inclusion of control variables (Becker, Antic, Carlson, Edwards, & Spector, 2016; Spector & Brannick, 2011). The inclusion of each demographic variable as a potential control is independently considered using these criteria and is detailed in the following section. Given that all participants are employed by the same organization, work-family culture and formal work-family policies are inherently constant across employees. In addition, the variance in ratings between supervisors/workgroups was accounted for.

Supervisor survey. As described above, supervisors completed the SLMX scale for a randomly sampled group of their subordinates.

Supervisor-rated leader-member exchange. Supervisor-rated LMX was assessed using Maslyn and Uhl-Bien's (2001) seven-item scale. Rather than using a mirrored version of the LMX-7 to assess what the supervisor provides to the subordinate via LMX (e.g., Liden, Wayne, & Stilwell, 1993), Maslyn and Uhl-Bien's (2001) scale is a parallel version that is worded to capture what the supervisor receives from the subordinate in this relationship. LMX scholars have recently advocated for the mirrored approach to supervisor-rated LMX as it best captures the exchanges inherent in their dyadic relationship (e.g., Liden et al., 2015; Matta et al., 2015). A sample item is, "How would you characterize your working relationship with this employee?" The 5-point Likert-type response scale for this measure is anchored by 1 (*e.g. extremely ineffective*) and 5 (*e.g. extremely effective*), though the anchors vary by item. Maslyn and Uhl-Bien (2001) reported coefficient alpha reliability estimates of .92. Coefficient alpha for the current study was .90. The complete measure is presented in Appendix E.

CHAPTER III

RESULTS

Power Analysis

Mplus version 7.4 software (Muthén & Muthén, 2015) was used to conduct a proactive (a priori) Monte Carlo simulation study for the purposes of a power analysis and sample size planning (Wolf, Harrington, Clark, & Miller, 2013). Using syntax adapted from Muthén and Muthén (2002), a Monte Carlo simulation was conducted for the fully latent structural equation model with both supervisor and subordinate-rated LMX included as independent variables, the ideals sub-scales included as mediators, and WIF and WFE modeled as dependent variables. The purpose of the proactive Monte Carlo simulation study was to determine the requisite sample size to detect an effect of a given size ($\beta = .10$) with a given degree of confidence (Cohen et al., 2003; Wolf et al., 2013). This analysis consisted of a stepwise procedure in which the sample size of each model is modified based on the stability of the solution and adequate model fit as determined by RMSEA ($\leq .05$), CFI ($\geq .95$), and SRMR ($\leq .05$). Following the procedure outlined by Wolf et al. (2013), the initial proactive Monte Carlo simulation study was conducted with a sample size of 200 as this number has been commonly referred to as the minimum for structural equation modeling (Kline, 2011). The resulting solution converged, demonstrated power to be at least 80% for all parameters of interest ($\alpha = .05$), and yielded proper solutions (i.e., CI_{95%} contained population value in at least 90% of the simulations, acceptable standard error estimates; Wolf et al., 2013). In addition, this simulation revealed that a sample of 200 participants provided enough statistical power for model fit indices to detect model (mis)fit. Additional Monte Carlo simulations were conducted with sample sizes of 180, 160, and 140 until models did not achieve adequate statistical power for all model parameters. The set of proactive Monte Carlo simulations revealed a minimum sample size of 160 required to detect an effect

with at least 80% power at $\alpha = 05$. This is in line with findings reported by Wolf et al. (2013) and Muthén and Muthén (2002), who demonstrated that fully latent structural equation modeling with mediated effects tend to achieve adequate power with smaller sample sizes than more complex models (e.g., latent growth, mixture models) and models with extreme missing data. The study sample size of 133 matched dyads approached but did not meet these recommendations, increasing the likelihood of Type-II error when conducting the analyses using a fully latent structural equation model (Cohen, Cohen, West, & Aiken, 2003). Because of this, the model parameter estimates are likely to have wider sampling distributions (i.e., larger variance) and effects that are practically important may not be detectable (Cohen et al., 2003). As a result, the full model was tested using Edwards and Lambert's (2007) path analytic procedures, which detail the combination of latent variable measurement modeling and path analysis using a stepwise rather than simultaneous procedure.

Data Analytic Strategy

The data were cleaned and inspected for outliers. Means, standard deviations, reliability estimates, and intercorrelations among the study variables are depicted in Table 2. The correlation matrix indicates that the majority of the focal constructs of interest were significantly related and in the expected directions, however, contrary to expectations, SLMX was not significantly related to WIF, $r = -.084$, $p = .339$, and location flexibility i-deals were not significantly related to WFE, $r = .131$, $p = .070$.

Table 2

Descriptive Statistics and Intercorrelations for Study Variables

Variable	<i>M</i>	<i>SD</i>	1	2	3	4	5	6	7	8	9	10	11	12	13	14
1. Gender [^]	.29	.45	-													
2. Relationship ^{^a}	.70	.40	-.01	-												
3. Children ^a	1.37	1.25	.00	.48	-											
4. Work Hours ^a	42.65	4.52	.01	.03	-.13	-										
5. Organization Tenure ^a	15.43	11.65	-.08	.15	.33	.12	-									
6. Supervisor Tenure ^a	3.43	3.12	.11	.03	.20	.05	.28	-								
7. SLMX ^b	4.12	.71	-.08	.28	-.00	-.06	.16	.11	(.90)							
8. LMX	3.90	.86	-.07	.06	.01	-.21	-.02	.05	.46	(.94)						
9. Schedule I-deals	4.21	.94	.10	.05	.02	-.26	-.04	-.04	.18	.24	(.90)					
10. Location I-deals	3.98	1.15	.15	.18	.18	-.21	-.08	.01	.20	.23	.73	(.95)				
11. Task I-deals	3.73	.88	-.11	.18	.04	-.01	-.01	.05	.43	.45	.24	.11	(.85)			
12. Career I-deals	3.58	.89	.08	.09	.01	-.14	-.11	.09	.32	.48	.52	.40	.66	(.79)		
13. WIF	3.28	1.52	-.01	.12	.03	.44	.08	.08	-.08	-.27	-.32	-.18	-.07	-.17	(.94)	
14. WFE	4.78	1.27	.19	-.03	.01	-.24	-.11	-.05	.36	.35	.18	.13	.43	.40	-.28	(.85)

Note. $n = 191$ unless otherwise noted. Values in parentheses represent coefficient alphas. Statistically significant correlations ($p < .05$) are indicated in bold for ease of interpretation. Gender coded 0 = male, 1 = female; Relationship = Marital status coded 0 = single, 1 = married/living as married; Children = Number of children; Work Hours = Average hours worked per week; Organization Tenure = Number of years employed at current organization; Supervisor Tenure = Number of years reporting to current immediate supervisor; SLMX = Supervisor-rated Leader-Member Exchange, LMX = Subordinate-rated Leader-Member Exchange; I-deals = Idiosyncratic deals; Schedule = Schedule flexibility; Location = Location flexibility; Career = Career development; WIF = Work interference with family; WFE = Work-to-family enrichment.

[^] indicates that Spearman's rank order correlation (ρ) is reported, ^a indicates $n = 166-169$, ^b indicates $n = 133$.

Little's (1988) test was used to determine whether not missing data was missing completely at random (MCAR) for justification for addressing missing data with expectation maximization (EM) imputation. SLMX, LMX, and the set of control variables were entered as predictors, and the four forms of i-deals, WIF, and WFE were entered as predicted variables in IBM SPSS Statistics Version 22. Little's test indicated that data may be assumed to be MCAR, $\chi^2(33) = 42.54, p = .123$, and as a result, missing data were addressed by using expectation maximization (EM) imputation in Mplus Version 7.4. EM uses maximum likelihood parameter estimation to impute the expected value of each missing data point by using the respective respondent's previous answers (Allison, 2002; Cohen, et al., 2003).

Given the nested data structure (i.e., subordinates are nested within supervisor/branch), the first step of the analysis was to assess potential non-independence of data (Weinfurt, 2010). Multi-level modeling (MLM) in Mplus 7.4 was used to conduct supplementary analyses that examine the amount of model variance that resides between supervisors (Bliese & Hanges, 2004). Put simply, the MLM was used to examine if level-1 predictors and parameters vary by supervisor/branch. First, a model in which only the random effect for each intercept (i.e., supervisor) was entered with no predictors was analyzed to obtain the information necessary to calculate intraclass coefficient (ICC; i.e., the amount of variance in the outcome variables that exist between supervisors; Bell, Ene, Smiley, & Schoeneberger, 2013; Raudenbush & Bryk, 2002). The ICC was calculated using the following equation, where τ_{00} represents the extent to which the group (supervisor/branch) differs from the grand mean (between-variance), and σ^2 represents the extent to which the person differs from the group mean (within-variance).

$$ICC = \frac{\tau_{00}}{(\tau_{00} + \sigma^2)}$$

Ultimately, the ICC describes how much total variability in the model is driven by group-level rather than individual-level differences and provides justification for using MLM (Raudenbush & Bryk, 2002). Although guidelines vary widely in the literature, an ICC value $\geq .10$ has been most commonly cited as the baseline value to warrant MLM (Raudenbush & Bryk, 2002; Woltman, Feldstain, MacKay, & Rocchi, 2012). The ICC was calculated for each of the four mediating and two dependent variables. As depicted in Table 3, the ICCs for the between-supervisor models ranged from .01 to .25, justifying the use of MLM for analyses. MLM is appropriate for nested data to account for non-independence and to correct standard errors, chi-square, and parameter estimates (Bell et al., 2013; Raudenbush & Bryk, 2002).

Table 3

Intraclass Correlation Coefficients

Variable	τ_{00}	σ^2	ICC
Task i-deals	0.03	0.75	0.04
Career i-deals	0.06	0.72	0.08
Schedule flexibility i-deals	0.15	0.76	0.16
Location flexibility i-deals	0.34	1.04	0.25
Work interference with family	0.01	1.60	0.01
Work-family enrichment	0.27	2.06	0.12

Note. ICC values were calculated without control variables in model. τ_{00} = between supervisor/branch variance; σ^2 = within supervisor/branch variance; ICC = intraclass correlation coefficient.

Measurement Model

Mplus 7.4 (Muthen & Muthen, 2015) was used to test the measurement model using *confirmatory factor analysis (CFA)*. Given the significant between-group variation identified in the previous steps, two unique confirmatory factor analyses were conducted (Dyer, Hanges, & Hall, 2005). First, the total sample matrix was used to test a conventional CFA in which the nested nature of the data is unaccounted for. Since the constructs of interest are latent variables, CFA was used to confirm that the scale items (indicators) are related to their corresponding factor (i.e., indicators should have standardized factor loadings greater than .70 to indicate convergent validity; Schumacker & Lomax, 2004). The seven items representing subordinate-rated LMX were specified to load onto Factor 1, the seven items representing supervisor-rated LMX were specified to load onto Factor 2, the three items representing location flexibility were specified to load onto Factor 3, the four items representing schedule flexibility were specified to load onto Factor 4, the three items representing task i-deals were specified to load onto Factor 5, the three items representing career i-deals were specified to load onto Factor 6, the three items representing WFE were specified to load onto Factor 7, and the five items representing WIF were specified to load onto Factor 8. Following guidelines from Schumacker and Lomax (2004), both the global fit measures of chi-square and root mean square error of approximation (RMSEA) were assessed. Model chi-square is the most common fit test that compares the model's predicted covariances to the population covariance matrix. This is a test of poor fit, such that a significant chi-square indicates lack of satisfactory model fit (Kline, 2011). In large samples (i.e., $n \geq 200$), small differences between the proposed and observed model may result in a significant chi-square value, increasing the likelihood of Type II error (Bentler, 1990). Similarly, RMSEA is an index of poor fit, where a value of zero represents the best fit (Kline,

2011). There is good model fit when the RMSEA is less than or equal to .05 (Schumacker & Lomax, 2004), though some researchers have suggested .06 as a more practical indicator (Hu & Bentler, 1999).

Following advice from Schumacker and Lomax to not rely solely on any single indicator of model fit, the comparative fit index (CFI) and standardized root-mean-square residual (SRMR) were also assessed (Bentler, 1990; Kline, 2011). CFI compares the fit of the proposed model to that of an independent model in which the variables are assumed to be uncorrelated (Hu & Bentler, 1999). The recommendation for good fit is a CFI value of greater than or equal to .95 (Kline, 2011). SRMR is a measure of the difference between the predicted and observed correlations. SRMR values range from zero to 1.0 with perfect fit indicated by a value of zero. Good-fitting models should obtain SRMR values less than .05 (Hu & Bentler, 1999; Kline, 2011). As shown in Table 4, this measurement model yielded the following fit statistics: $\chi^2(532) = 842.38, p < .001, RMSEA = .055, CI_{90} = (.048, .062), CFI = .94, SRMR = .059$. The fit statistics for the measurement model provided evidence of good model fit. As expected with this study's large sample size, the chi-square statistic for global fit was significant, indicating poor model fit. The RMSEA value of .055 indicated acceptable model fit, and inspection of RMSEA revealed that the upper bound of the 90 percent confidence interval did not exceed .1, providing further evidence of good model fit. The CFI approached but did not exceed .95, and the SRMR value of .059 exceeded Hu and Bentler's (1999) guideline of .05, which indicated that model fit was inadequate using these indices. An inspection of the model modification indices suggested that the root cause of the model misfit was attributable to substantial within-scale covariances between the error terms of items (e.g., SFLEX1 WITH SFLEX2; WIF1 WITH WIF2). In

addition, all model indicators had standardized factor loadings greater than .70 with one exception (WFE item 1, $\lambda = .55$, see Figure 4).

To provide evidence of discriminant validity, the fit of the 8-factor measurement model was compared to a number of alternative measurement models: a 1-factor model in which all items were specified to load onto a single factor, a 3-factor model in which the items representing LMX, i-deals, and work-family experiences each loaded onto their respective factor, 4-factor model in which LMX and SLMX items were each specified to load onto their own unique factors, and a 6-factor model in which schedule and location flexibility were specified to load onto a higher-order *flexibility* factor, and task and career i-deals were specified to load onto a higher-order *developmental* factor. The 8-factor model provided the best fit to the data (see Table 4).

Table 4

Comparison of Model Fit for Hypothesized Model

	χ^2	<i>df</i>	CFI	RMSEA	SRMR	$\Delta\chi^2$	Δdf
Expected 8-Factor Model	842.38	532	.94	.06	.06		
1-Factor Model	3992.04	560	.34	.18	.17	3149.66*	28
3-Factor Model	2387.76	557	.65	.13	.16	1545.38*	25
4-Factor Model	2024.24	554	.72	.12	.14	1181.86*	22
6-Factor Model	1218.69	545	.87	.08	.08	376.31*	13

Note. The goodness-of-fit for the expected 8-factor model was compared to each alternative model. * $p < .001$

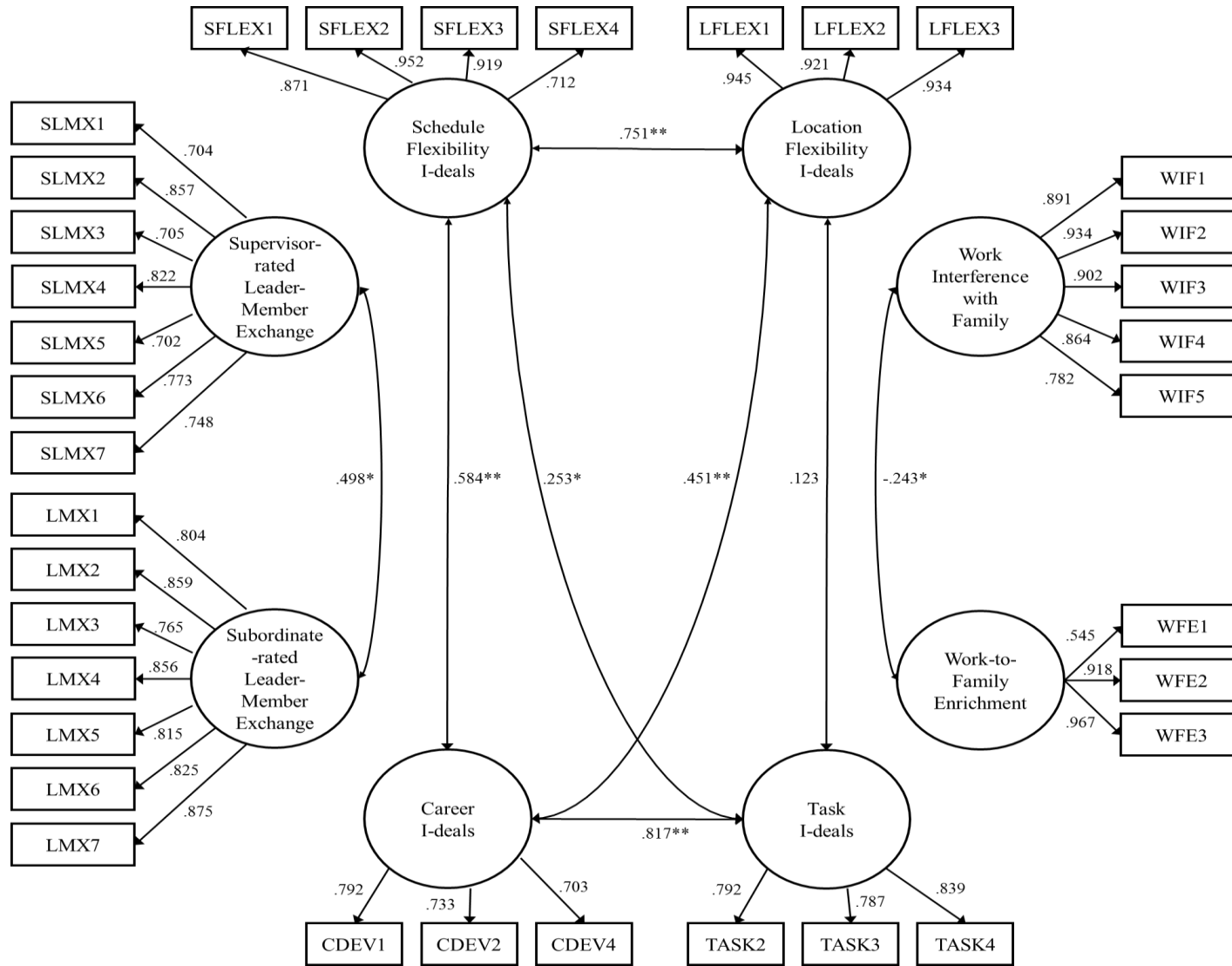

Figure 4. Confirmatory factor analysis for hypothesized model with standardized parameter estimates.

Note: * $p < .05$, ** $p < .001$

Second, multilevel CFA techniques were applied to account for potential non-independence due to the hierarchical nature of the data (Dyer et al., 2005; Grilli & Rampichini, 2007). However, given the large number of parameters for the fully latent solution, estimation problems, including a failure to converge to a solution, would not permit the testing of the full measurement model using multilevel CFA. This is a problem that frequently occurs when the number of parameters greatly exceeds the number of between-level groups (Muthen & Muthen, 2015). As a result, between-supervisor variance was accounted for by grouping the complex data by branch. This CFA was conducted on the full measurement model to obtain the correct standard errors for level-1 analyses. This measurement model yielded fit statistics similar to those of the conventional, single-level CFA: $\chi^2(532) = 848.73, p < .001$, RMSEA = .056, CI₉₀ = (.049, .063), CFI = .94, SRMR = .059. The model indicators mirrored those depicted in Figure 4, and again, only one WFE item had a standardized factor loading less than 0.70.

Path Model

Mplus 7.4 was used to test the proposed model using Edwards and Lambert's (2007) path analytic procedures for examining moderated indirect effects. Mplus 7.4 permits path analyses to be conducted at individual or multiple levels (Muthén & Muthén, 2015). Path analysis provides advantages over other forms of regression in that it affords the capacity to test multiple dependent variables and the ability to analyze overall models rather than individual relationships (Byrne, 2012; Kline, 2011; Schumacker & Lomax, 2004). Since the current study does not hypothesize between-group effects, differences across supervisors were controlled for by grouping the complex data by branch. This procedure accounted for non-independence of data, and provided corrected standard errors, chi-square, and parameter estimates.

Scholars have recently emphasized the importance of both theoretical and empirical justification when considering the use of potential control variables (Becker, Antic, Carlson, Edwards, & Spector, 2016; Spector & Brannick, 2011). Although Spearman's rank order correlation indicated that gender shared a statistically significant relationship with WFE, $\rho = .19$, $p = .011$, there is not enough theoretical rationale to suggest that men and women experience WFE differently. Scholars have suggested that men and women may differentially integrate their work and family roles (McNall et al., 2011) and utilize resources differently (Wayne et al., 2007). However, researchers conceptually linking gender to WFE tend to do so by positioning it as a moderator of other relationships (e.g., Baral & Bhargava, 2011; McNall et al., 2011; Wayne et al., 2007). Therefore gender was not controlled for in the hypothesis tests. Although conceptually relevant given that LMX quality develops over time (Graen & Scandura, 1987), neither years reporting to one's immediate supervisor nor organizational tenure (in years) were significantly related to any of the study's focal variables. Finally, working adults who have greater weekly time commitments to their jobs theoretically should have fewer resources (e.g., time, energy) per week that can be dedicated to fulfilling their family role obligations. As depicted in Table 2, average work hours per week was significantly related to both WIF, $r = .44$, $p < .001$, and WFE, $r = -.24$, $p = .002$.

The model was tested both with and without average work hours per week as a control variable, and although some of the model parameter estimates varied significantly ($\geq .10$) between the two models (Becker et al., 2016), there was a significant amount of missing data on the average hours worked per week variable and its inclusion in the matched sample would reduce the sample size to 114. Due to the study being statistically underpowered (Becker, 2005), average hours worked per week was not included in the model as a control variable. The model

without controls is presented in Figure 5 and is referenced with respect to hypothesis tests moving forward. For ease of interpretation, non-significant paths are omitted from the model in Figure 5. The full model with all paths depicted is presented in Appendix F. Based on recent recommendations (Becker et al., 2016; Bernerth & Aguinis, 2016; Spector & Brannick, 2013), the model controlling for average work hours is also presented in Appendix G.

LMX and SLMX were mean-centered prior to creating the interaction term to eliminate non-essential multicollinearity and facilitate interpretation of the results (Cohen et al., 2003). All effects were analyzed using bias-corrected confidence intervals with bootstrapping at 5,000 iterations. To test support for the model hypotheses, the statistical significance, direction and magnitude of (a) bivariate correlations (see Table 2), and/or (b) the path parameter estimates were assessed (see Figure 5; Schumacker & Lomax, 2004).

The set of predictors contributed a significant proportion of variance in WIF (.14), WFE (.25), task (.29), and career development i-deals (.27), but not schedule flexibility (.06), or location flexibility i-deals (.06). Hypothesis 1 stated that a statistically significant negative relationship would exist between WIF and WFE. An inspection of the correlation matrix indicated that WIF and WFE were negatively related, $r = -.28, p < .001$. In the hypothesized model, WIF and WFE were also negatively related, $b = -.369 (-.683, -.054), \beta = -.235 (-.419, -.052)$. Hypothesis 1 was supported. In support of Hypothesis 2, subordinate-rated LMX and WIF were negatively related in both the correlation matrix, $r = -.27, p < .001$, and path model, $b = -.451 (-.777, -.125), \beta = -.265 (-.453, -.076)$. Hypothesis 3, which stated that supervisor-rated LMX and WIF would be negatively related, was not supported. Both the Pearson's r correlation coefficient for this relationship and parameter estimate in the path model were non-significant and in the positive direction, $r = .08, p = .303$, and $b = .071 (-.411, .554), \beta = .033 (-.192, .259)$.

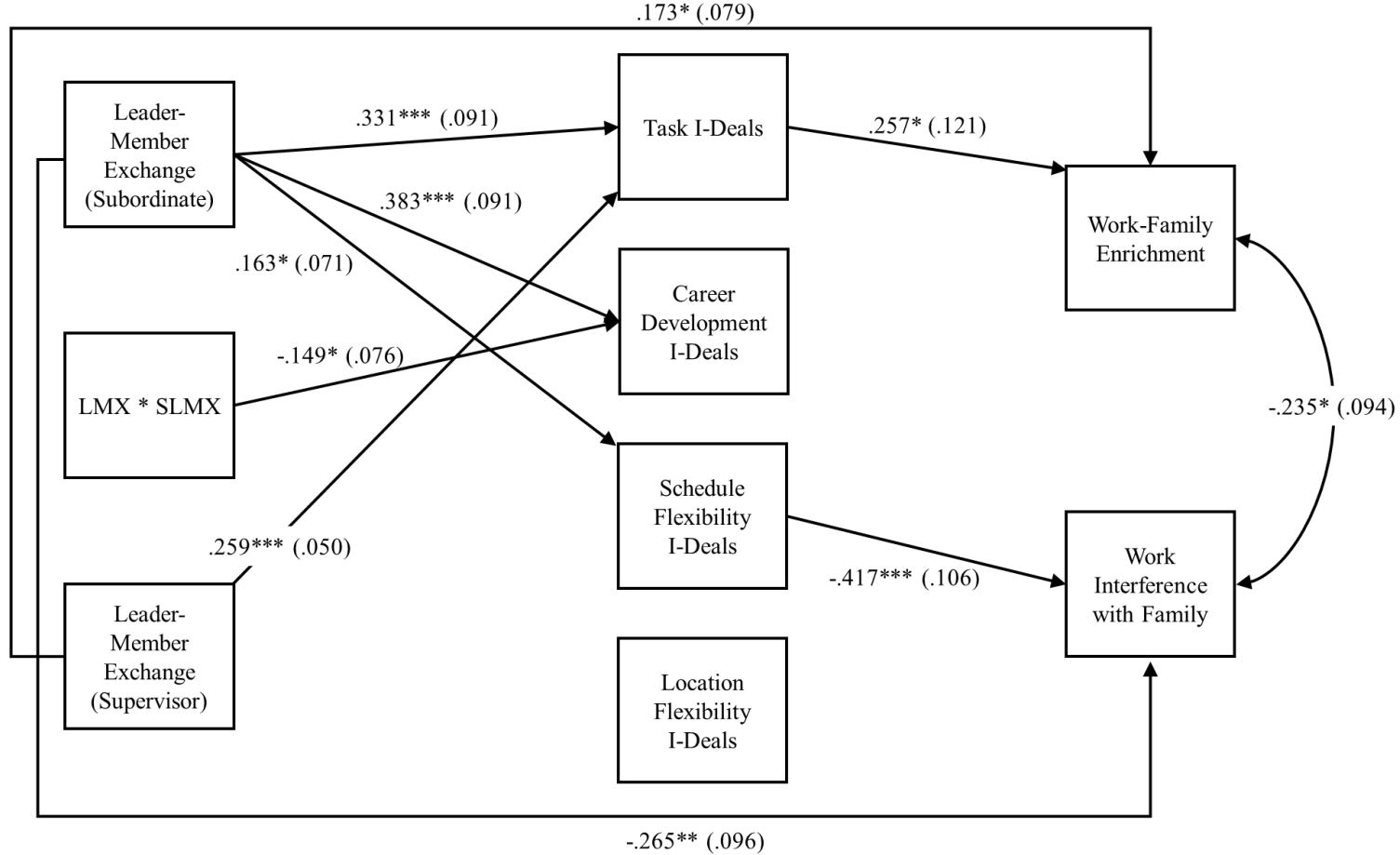

Figure 5. The hypothesized model with standardized parameter estimates. Please note that non-significant paths are omitted for ease of interpretation. Please see Appendix F for the full model. The number in parentheses represents the standard error for the standardized path. * $p < .05$, ** $p < .01$, *** $p < .001$.

Support for Hypothesis 4, which stated that supervisor-rated LMX would moderate the negative relationship between subordinate-rated LMX and WIF, was also examined in two ways. First, the model parameter estimate for the path between the interaction term and WIF was specified and examined with all other variables included in the model, $b = -.012 (-.386, .361)$, $\beta = -.006 (-.176, .165)$. Second, the analysis was conducted without the four idiosyncratic deals in the model. As shown in Figure 6, the path between the interaction term and WIF remained non-significant and in the negative direction, $b = -.027 (-.407, .353)$, $\beta = -.012 (-.186, .162)$. Hypothesis 4 was not supported.

Hypothesis 5 stated that there would be a positive relationship between subordinate-rated LMX and WFE. As shown in Table 2, LMX and WFE were positively correlated, $r = .35$, $p < .001$. However, in the full model, the parameter estimate for this path was not statistically significant, $b = .058 (-.237, .353)$, $\beta = .039 (-.163, .242)$. Hypothesis 5 was partially supported. Hypothesis 6, which stated that SLMX and WFE would be positively related, was supported. The two variables were positively correlated, $r = .36$, $p < .001$, and remained directly related with all other variables included in the path model, $b = .319 (.036, .601)$, $\beta = .173 (.018, .329)$.

Hypothesis 7, which proposed that supervisor-rated LMX would moderate the positive relationship between subordinate-rated LMX and WFE, was tested by again examining the model parameter estimate for the path between the interaction term and WFE, $b = -.378 (-.578, -.178)$, $\beta = -.201 (-.315, -.088)$, and then conducting the analysis without idiosyncratic deals included in the model, $b = -.449 (-.668, -.229)$, $\beta = -.239 (-.365, -.113)$. Contrary to expectations, the interaction term was statistically significant in the negative direction, suggesting that SLMX has an attenuating effect on the positive relationship between LMX and WFE (see Figure 6). This was further confirmed using a test of simple slopes (see Figure 7). At low levels of SLMX

(*ISD* below mean), the relationship between LMX and WFE was positive and statistically significant, simple slope = .630, $t = 3.47$, $p = .001$. However at high levels of SLMX (*ISD* above mean), the relationship between LMX and WFE was not statistically significant, simple slope = -.27, $t = -1.17$, $p = .243$. Hypothesis 7 was not supported.

Hypothesis 8 stated that LMX and i-deals would be positively related. Bivariate correlations suggest that LMX is positively related to both types of developmental i-deals (H_{8A}), task $r = .45$, $p < .001$, career $r = .48$, $p < .001$, and positively related to both types of flexibility i-deals (H_{8B}), schedule $r = .24$, $p = .001$, location $r = .23$, $p = .001$. Examination of the path model parameter estimates also suggests that LMX is positively related to schedule flexibility i-deals, $b = .180$ (.014, .346), $\beta = .163$ (.025, .301), task i-deals, $b = .333$ (.132, .533), $\beta = .331$ (.152, .509), and career development i-deals, $b = .402$ (.199, .605), $\beta = .383$ (.205, .562), but not significantly related to location flexibility i-deals, $b = .154$ (-.058, .366), $\beta = .123$ (-.048, .294). Hypothesis 8A was supported, and Hypothesis 8B was partially supported.

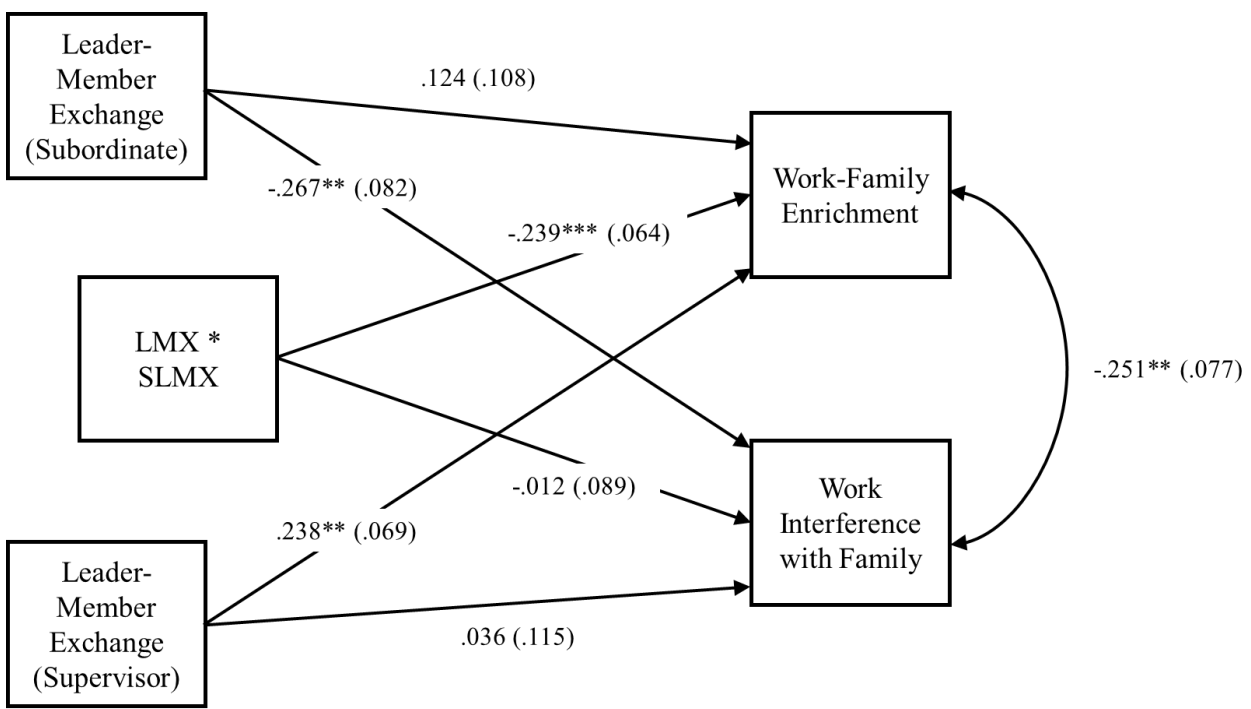

Figure 6. Interactive effects of subordinate-rated leader-member exchange (LMX) and supervisor-rated leader-member exchange (SLMX) on work-family experiences with standardized parameter estimates. Number in parenthesis indicates standard error for parameter estimate. * $p < .01$, ** $p < .001$.

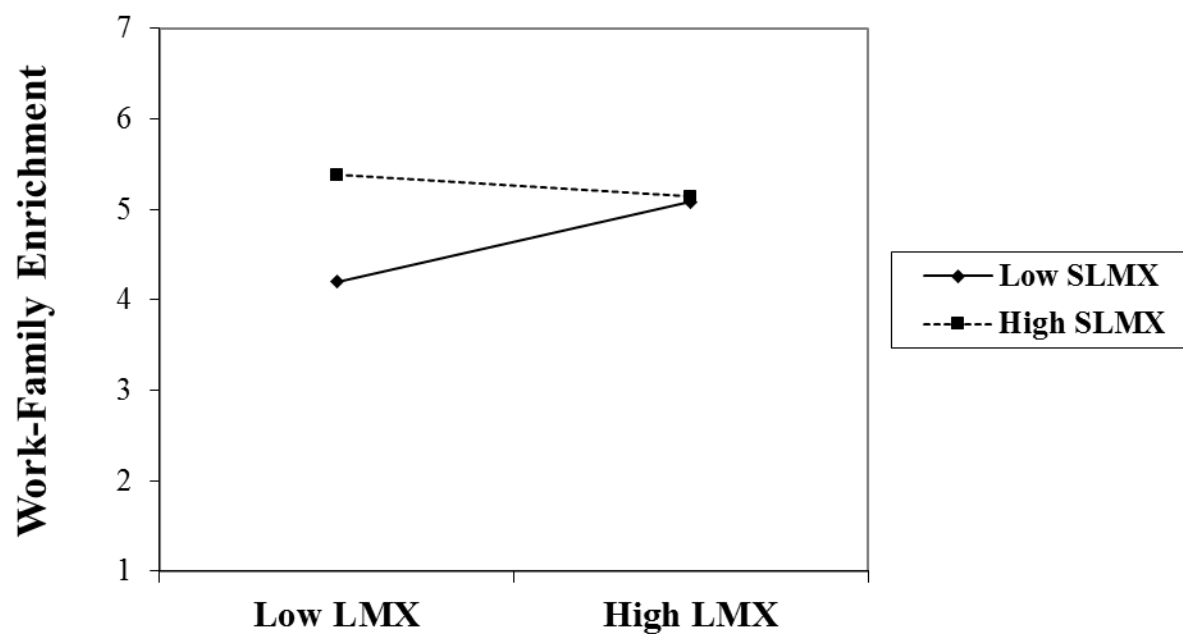

Figure 7. Simple slopes analysis of the relationship between LMX and WFE at high (+1SD) and low (-1SD) levels of SLMX

Hypothesis 9 stated that flexibility i-deals would be negatively related to WIF. Bivariate correlations revealed that both schedule flexibility i-deals, $r = -.32, p < .001$, and location flexibility i-deals, $r = -.18, p = .014$, were significantly related to WIF in the negative direction. In the full path model, these results held true for schedule flexibility i-deals, $b = -.643 (-.981, -.305)$, $\beta = -.417 (-.626, -.209)$, but not location flexibility i-deals, $b = .233 (-.100, .567)$, $\beta = .171 (-.075, .417)$. Hypothesis 9 was partially supported.

Hypothesis 10 stated that flexibility i-deals would be positively related to WFE. Bivariate correlations suggested that schedule flexibility was significantly related to WFE in the expected direction, $r = .18, p = .014$, but location flexibility i-deals were not significantly related to WFE, $r = .13, p = .070$. In the path model, however, neither schedule flexibility i-deals, $b = .058 (-.206, .322)$, $\beta = .044 (-.156, .244)$, nor location flexibility i-deals, $b = .090 (-.126, .306)$, $\beta = .077 (-.107, .261)$, were significantly related to WFE. Hypothesis 10 was partially supported.

Hypothesis 11 stated that developmental i-deals would be positively related to WFE. Bivariate correlations suggested that both task i-deals, $r = .43, p < .001$, and career development i-deals, $r = .40, p < .001$, were positively related to WFE. In the path model, the parameter estimate for the path between task i-deals and WFE was positive and statistically significant, $b = .373 (.005, .741)$, $\beta = .257 (.010, .515)$, however, the path between career development i-deals and WFE was not significant, $b = .120 (-.257, .497)$, $\beta = .086 (-.186, .359)$. Hypothesis 11 was partially supported.

To test the Hypotheses 12-14, which state that flexibility i-deals mediate the relationships between LMX and WIF (H_{12}) and WFE (H_{13}), and that developmental i-deals mediate the relationship between LMX and WFE (H_{14}), model indirect effects were examined in the full path model. Significant indirect effects on the work-family outcomes via i-deals indicate mediation

(Muthén & Muthén, 2015). The mediation is considered partial if the indirect effect is statistically significant and the direct effect of LMX on the dependent variable of interest remains statistically significant. If this direct path from LMX to the dependent variable becomes non-significant, then it is determined that i-deals completely mediate the relationship between LMX and the outcome of interest (Edwards & Lambert, 2007; Preacher, Rucker, & Hayes, 2007).

Hypothesis 12 was not supported, as the indirect effects from LMX to WIF via schedule flexibility i-deals, $b = -.116$ ($-.236, .004$), and via location flexibility i-deals, $b = .036$ ($-.038, .110$), were both non-significant. Hypothesis 13 was also not supported, as the indirect effects from LMX to WFE via schedule flexibility i-deals, $b = .010$ ($-.038, .059$), and via location flexibility i-deals, $b = .014$ ($-.022, .049$), were not statistically significant. Hypothesis 14 was partially supported. The indirect effect from LMX to WFE via task i-deals was significant and in the expected direction, $b = .144$ ($.011, .258$). However, the same indirect effect through career development i-deals was not statistically significant, $b = .048$ ($-.110, .207$). The direct effect from LMX to WFE was not statistically significant in the full model, indicating that task i-deals fully mediated this relationship.

The indirect effect hypotheses were also examined in a model in which idiosyncratic deals and work-family experiences were not regressed on SLMX and the interaction term to conserve explained variance in the predicted variables. These analyses demonstrated support for two of the three indirect effect hypotheses. Without SLMX and the interaction term included in the model, Hypothesis 12 received partial support, as schedule flexibility i-deals partially mediated the relationship between LMX and WIF, $b = -.182$ ($-.307, -.056$), $\beta = -.102$ ($-.168, -.037$). The same indirect effect via location flexibility i-deals remained not statistically

significant, $b = .071$ (-.024, .167), $\beta = .040$ (-.012, .092). Without SLMX and the interaction term, task i-deals partially mediated the relationship between LMX and WFE, $b = .170$ (.011, .330), $\beta = .115$ (.011, .219), as the direct path between LMX and WFE became statistically significant in this model, $b = .237$ (.016, .458), $\beta = .160$ (.007, .312). The indirect effect from LMX to WFE via career development i-deals, $b = .108$ (-.053, .269), $\beta = .073$ (-.036, .181), and both forms of flexibility i-deals, schedule, $b = -.003$ (-.069, .063), $\beta = -.002$ (-.047, .043), location, $b = .004$ (-.044, .051), $\beta = .003$ (-.030, .035), remained non-significant in this model.

Hypothesis 15 stated that SLMX would be positively related to both flexibility i-deals and developmental i-deals. Bivariate correlations suggest that SLMX is positively related to both types of developmental i-deals (H_{15A}), task $r = .43$, $p < .001$, career $r = .32$, $p < .001$, and positively related to both types of flexibility i-deals (H_{15B}), schedule $r = .18$, $p = .035$, location $r = .20$, $p = .019$. Examination of the path model parameter estimates also suggests that SLMX is positively related to task i-deals, $b = .328$ (.190, .466), $\beta = .259$ (.160, .358), but is not significantly related to career development i-deals, $b = .146$ (-.022, .314), $\beta = .110$ (-.014, .235), schedule flexibility i-deals, $b = .133$ (-.123, .388), $\beta = .095$ (-.081, .272), location flexibility i-deals, $b = .204$ (-.139, .546), $\beta = .130$ (-.082, .341). Hypothesis 15_A was partially supported, and Hypothesis 15_B was supported with respect to task i-deals, but not career development i-deals.

Hypothesis 16, which stated that that SLMX would moderate the positive relationships between LMX and developmental (H_{16A}) and flexibility i-deals (H_{16B}), was examined in two ways. First, the model parameter estimate for the path between the interaction term and each type of i-deal was examined, task, $b = -.118$ (-.308, .072), $\beta = -.091$ (-.240, .058), career development, $b = -.201$ (-.417, -.015), $\beta = -.149$ (-.313, -.015), schedule, $b = -.071$ (-.287, .144), $\beta = -.050$ (-.204, .103), location, $b = -.109$ (-.333, .116), $\beta = -.068$ (-.209, .174). Second, the analysis was

conducted using hierarchical multiple regression in SPSS version 22. LMX and SLMX were mean-centered and entered into the first step of four separate regression analyses for each of the four types of i-deals. The interaction term was then added in the second step of each hierarchical multiple regression. As shown in Table 5, SLMX and LMX accounted for statistically significant variance in task (29%), career development (24%), location (6%), and schedule (6%) flexibility i-deals. The addition of the interaction term in Step 2 contributed an additional 3 percent variance in the career development model, $F(1,129) = 3.96, p = .048$. Similar to the path model, the regression coefficient for the interaction term was negative, $b = -.201, \beta = -.149$, indicating that SLMX has an attenuating effect on the relationship between LMX and career development i-deals. This was further confirmed using a test of simple slopes (see Figure 8). At low levels of SLMX (*ISD* below mean), the relationship between LMX and career i-deals was positive and statistically significant, simple slope = .603, $t = 4.77, p < .001$. However at high levels of SLMX (*ISD* above mean), the relationship between LMX and career i-deals was not statistically significant, simple slope = .201, $t = 1.30, p = .197$. Hypothesis 16 was not supported.

Table 5.

Hierarchical Multiple Regression of LMX and Idiosyncratic Deals

Variable	Task				Career				Schedule				Location			
	B	β	t	R^2	B	β	t	R^2	B	β	t	R^2	B	β	t	R^2
Step 1				.29				.24				.06				.06
LMX	.36	.35	4.24		.44	.42	4.91		.19	.18	1.83		.18	.14	1.47	
SLMX	.34	.27	3.25		.17	.13	1.52		.14	.10	1.06		.22	.14	1.44	
Step 2				.01				.03				.00				.00
LMX	.33	.33	3.86		.40	.38	4.38		.18	.16	1.65		.15	.12	1.25	
SLMX	.33	.26	3.09		.15	.11	1.29		.13	.10	.98		.20	.13	1.34	
Interaction	-.12	-.09	-1.16		-.20	-.15	-1.96		-.07	-.05	-.55		-.11	-.07	-.75	
Total R^2				.30				.27				.06				.06

Note: Effects significant at $p < .05$ are bolded for ease of interpretation

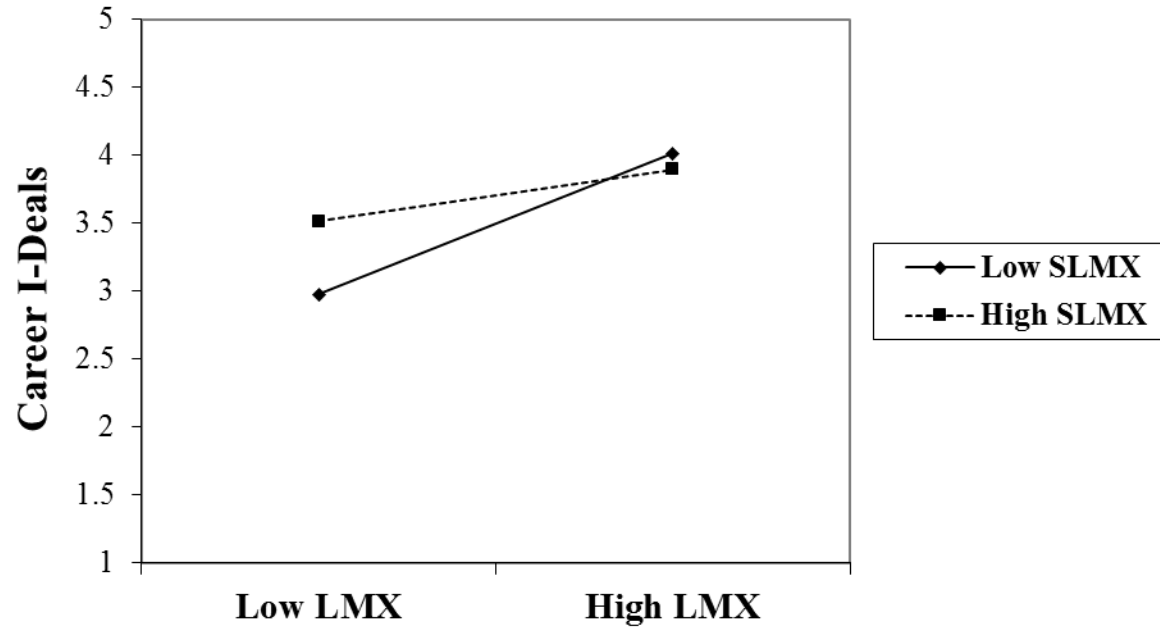

Figure 8. Simple slopes analysis of the relationship between LMX and career development i-deals at high (+1SD) and low (-1SD) levels of SLMX

Finally, a moderated mediation model was tested to assess the whether the strength of the mediated effects from LMX to work-family outcomes via i-deals become stronger as SLMX is higher (Cheung & Lau, 2015; Preacher et al., 2007). In this model (which is slightly different from Figure 5 in that the work-family variables are not regressed onto SLMX and the interaction term), the mediators (developmental and flexibility i-deals) are regressed on mean-centered SLMX and LMX, and the interaction term, and the dependent variables are regressed on the mediators (i-deals) and independent variable (LMX; see conceptual model in Figure 9). Conditional indirect effects are then calculated by examining the indirect effect at the mean value, and one standard deviation below and above the mean value of the moderator (SLMX). Hypotheses 17 A-C expected the mediated effect of LMX on work-family outcomes via i-deals to be statistically significant at high levels (*ISD* above mean) of supervisor-rated LMX, but not statistically significant at low levels (*ISD* below mean).

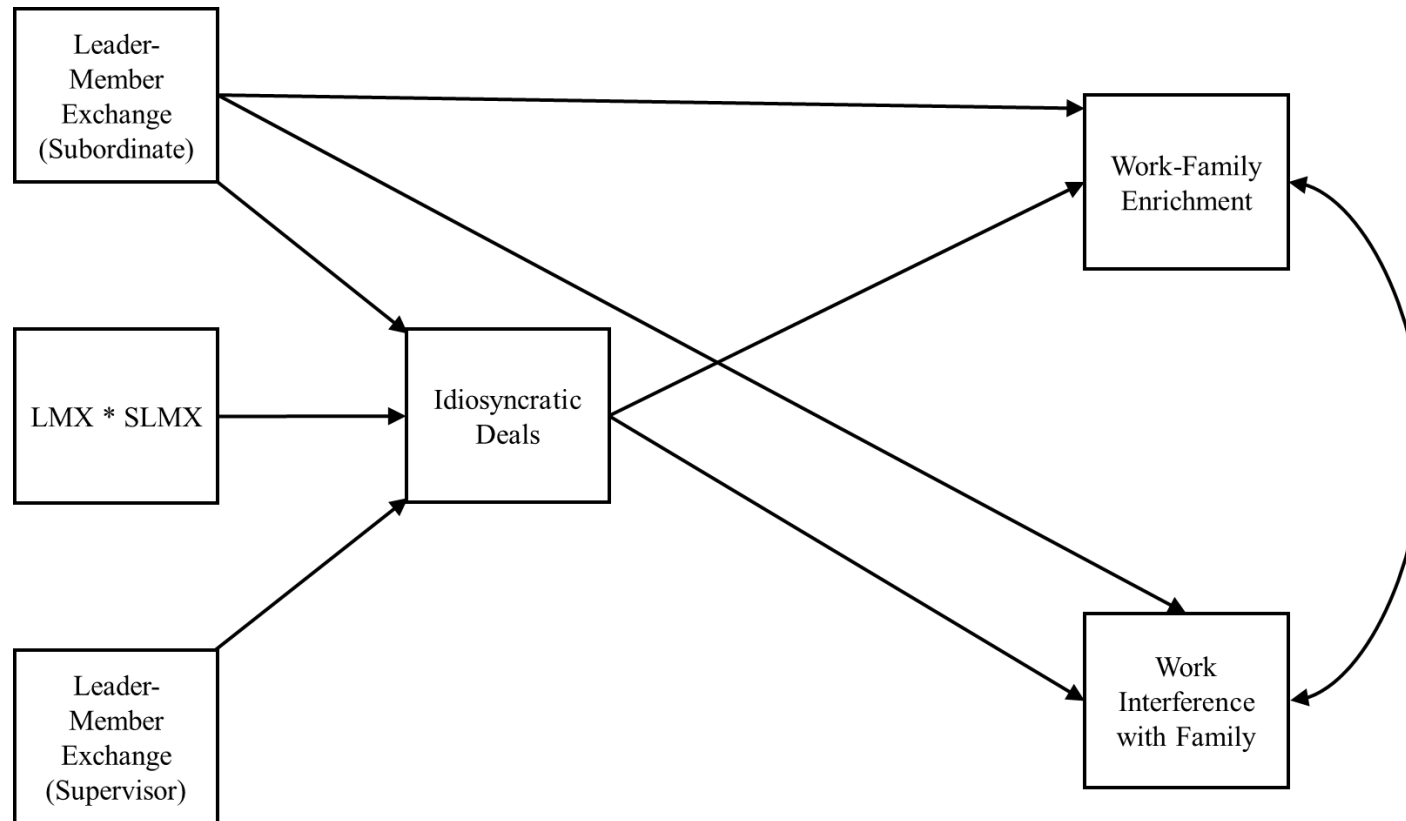

Figure 9. Conceptual model of a moderated mediation model with conditional indirect effects. The dependent variables (work-family experienced) are not regressed on the interaction term or moderator (SLMX). Instead, the indirect effect of LMX on the dependent variables via the mediator (idiosyncratic deals) is examined at low (-1SD below the mean), mean, and high (1SD above the mean) levels of SLMX.

Conditional indirect effects for each of the moderated mediation hypotheses are presented in Table 6 for WFE and Table 7 for WIF. Hypothesis 17_A stated that the indirect effect between LMX and WFE via developmental i-deals would be stronger at higher levels of SLMX. Contrary to expectations, the conditional indirect effect for task i-deals was statistically significant at low levels of SLMX, $b = .115 (.024, .206)$, $SE = .061$, but not at mean, $b = .083 (-.013, .178)$, $SE = .049$, or high SLMX, $b = .050 (-.091, .191)$, $SE = .072$. The conditional indirect effects for career development i-deals were not statistically significant at any level of SLMX. Hypothesis 17_B stated that the indirect effect between LMX and WFE via flexibility i-deals would be stronger at higher levels of SLMX. The conditional effects for schedule flexibility and location flexibility i-deals were not statistically significant at any level of SLMX.

Hypothesis 17_C stated that the indirect effects between LMX and WIF via flexibility i-deals would be stronger at higher levels of SLMX. Contrary to expectations, the conditional indirect effect for schedule flexibility i-deals was statistically significant at low levels of SLMX, $b = -.163 (-.335, -.010)$, $SE = .078$, but not at mean, $b = -.116 (-.236, .004)$, $SE = .062$, or high SLMX, $b = -.070 (-.268, .128)$, $SE = .101$. The conditional indirect effects for location flexibility i-deals were not statistically significant at any level of SLMX. Hypothesis 17 was not supported.

Table 6.

Conditional Indirect Effects of LMX on WFE at Low, Mean, and High Levels of SLMX

Model	Level	Direct Effect	Indirect Effect	Total Effects
Task I-Deals	SLMX _{Low}	.14	.12*	.26*
	SLMX _{Mean}	.14	.08	.22
	SLMX _{High}	.14	.05	.19
Career I-Deals	SLMX _{Low}	.14	.02	.16
	SLMX _{Mean}	.14	.02	.16
	SLMX _{High}	.14	.01	.15
Schedule I-Deals	SLMX _{Low}	.14	.01	.15
	SLMX _{Mean}	.14	.01	.15
	SLMX _{High}	.14	.00	.14
Location I-Deals	SLMX _{Low}	.14	.03	.17
	SLMX _{Mean}	.14	.02	.16
	SLMX _{High}	.14	.01	.15

Note: SLMX was -0.71 (1 SD below the mean) and 0.71 (1 SD above the mean) for low and high levels, respectively.

* $p < .05$, ** $p < .01$, *** $p < .001$.

Table 7.

Conditional Indirect Effects of LMX on WIF at Low, Mean, and High Levels of SLMX

Model	Level	Direct Effect	Indirect Effect	Total Effects
Task I-Deals	SLMX _{Low}	-.43**	.03	-.40**
	SLMX _{Mean}	-.43**	.02	-.41**
	SLMX _{High}	-.43**	.01	-.42**
Career I-Deals	SLMX _{Low}	-.43**	.03	-.40*
	SLMX _{Mean}	-.43**	.02	-.41*
	SLMX _{High}	-.43**	.01	-.42*
Schedule I-Deals	SLMX _{Low}	-.43**	-.16*	-.60**
	SLMX _{Mean}	-.43**	-.12	-.55**
	SLMX _{High}	-.43**	-.07	-.50**
Location I-Deals	SLMX _{Low}	-.43**	.06	-.37*
	SLMX _{Mean}	-.43**	.04	-.39*
	SLMX _{High}	-.43**	.03	-.41*

Note: SLMX was -0.71 (1 SD below the mean) and 0.71 (1 SD above the mean) for low and high levels, respectively.

* $p < .05$, ** $p < .01$, *** $p < .001$.

Finally, hierarchical polynomial regression and response surface methodology were used to examine Research Questions 1 and 2 regarding LMX congruence effects (Edwards, 2007; Edwards & Cable, 2009; Matta et al., 2015). Following the procedure outlined by Matta et al. (2015), i-deals, WIF, and WFE were each regressed on the five polynomial terms, supervisor-rated LMX, subordinate-rated LMX, the interaction term, supervisor-rated LMX², and subordinate-rated LMX² in separate models in Mplus 7.4. In the first step of each model, the dependent variable was regressed onto LMX and SLMX. The polynomial terms were added in the second step, and *F*-tests were conducted to examine whether or not the addition of the polynomial terms was statistically significant. The addition of the squared terms permit the researcher to fit the model to non-linear data, providing a more accurate depiction of the effect that LMX (in)congruence has on the variables of interest (Edwards & Cable, 2009).

Table 8 depicts the results from the polynomial regression for work-family experiences, and the results of the polynomial regression analyses for flexibility i-deals and developmental i-deals are shown in Tables 9 and 10, respectively. The first step of each of the polynomial models was statistically significant. LMX and SLMX contributed 6 percent of the variance in WIF, 15 percent of the variance in WFE, 6 percent of the variance in schedule flexibility i-deals, 6 percent of the variance in location flexibility i-deals, 29 percent of the variance in task i-deals, and 25 percent of the variance in career development i-deals. The addition of polynomial terms did not contribute statistically significant variance to the prediction of WIF, schedule flexibility, location flexibility, or task i-deals.

With respect to the WFE model, the addition of the polynomial terms contributed an additional 6 percent unique variance above and beyond mean-centered LMX and SLMX, $F(3,127) = 2.97, p = .034$. With all five terms included in the model, only SLMX, $\beta = .219 (.025,$

.413), $SE = .099$, and the interaction term, $\beta = -.193$ (-.385, -.001), $SE = .098$, were statistically significant. The addition of polynomial terms to the career development i-deals model, contributed an additional 6 percent variance above and beyond mean-centered LMX and SLMX, $F(3,127) = 3.54$, $p = .017$. With all five terms included in the model, LMX, $\beta = .462$ (.244, .679), $SE = .011$, the interaction term, $\beta = -.278$ (-.430, -.126), $SE = .077$, and the squared polynomial term for LMX, $\beta = .195$ (.015, .420), $SE = .101$, were statistically significant.

The polynomial terms were then exported to MYSTAT (Edwards, 2007) to plot the response surface. The response surface plots for WFE, WIF, schedule flexibility, location flexibility, task and career development i-deals are presented in Figures 10-15, respectively. Edwards and Cable (2009) describe three conditions that must be met to demonstrate a congruence effect. First, the curvature along the incongruence line of the response surface must be examined; if the curvature is negative, then the value of the dependent variable decreases when supervisor and subordinate-rated LMX differ in quality, whereas the value of the dependent variable increases due to incongruence effects if the curvature is positive (Edwards & Cable, 2009; Matta et al., 2015). The curvature of the LMX incongruence line ($b_3 - b_4 + b_5$) with respect to WFE was not statistically significant ($.14$, $t = -.82$, ns), however, the curvature of the LMX incongruence line with respect to career development i-deals was statistically significant ($.82$, $t = 4.78$, $p < .05$). Interestingly, the significant and positive curvature of the incongruence line indicates that career development i-deals are highest when supervisor and subordinate-rated LMX differ in quality.

Second, evidence of a congruence effect can be demonstrated if the value of the dependent variable is maximized (or minimized) when the ridge representing the highest point of the response surface is in congruence at every level of supervisor and subordinate-rated LMX

(Edwards & Cable, 2009; Matta et al., 2015). The results show that the 95% bias-corrected bootstrap confidence intervals for the slope and the intercept of the career development i-deals model were (.29, 1.33) and (-.10, .63), respectively. This analysis indicates that the slope and the intercept of the first principal axis are not significantly different from 1 and 0 respectively. Thus, the ridge of the response surface is located along the congruence line, ensuring that career development i-deals are minimized when supervisor-subordinate LMX ratings are congruent (Edwards & Cable, 2009). With respect to the WFE model, the 95% bias-corrected bootstrap confidence intervals for the slope and intercept were (-.62, .91) and (-.80, .28), respectively. Although the intercept of the first principal axis is significantly different from 0, the slope is not significantly different from 1. These results suggest that the value of WFE is not maximized at every level of LMX congruence.

Finally, the slope of the congruence line was examined to determine if the dependent variable is higher for congruence at higher LMX than lower levels. If these conditions hold true, it can be determined that LMX congruence is important for the outcome of interest, with the most favorable outcomes transpiring when congruence exists at higher levels of LMX. Both WFE and career development i-deals were highest at higher rather than lower levels of LMX congruence. The slope along the LMX congruence line ($b_3 + b_4 + b_5$) with respect to WFE (.54, $t = 6.69$, $p < .05$) and career development i-deals (.70, $t = 8.68$, $p < .05$) were statistically significant and in the positive direction, indicating that supervisor-subordinate congruence at higher levels of LMX was related to higher levels of these variables than was congruence at lower levels of LMX. In sum, LMX (in)congruence effects existed for only career development i-deals.

Table 8.

Polynomial Regression of Work-Family Experiences on LMX Congruence

Variable	Work Interference with Family				Work-Family Enrichment			
	B	β	t	R^2	B	β	t	R^2
Step 1				.06				.15
Constant	3.23		25.58		4.82		46.25	
LMX	-.45	-.26	-2.75		.27	.19	2.04	
SLMX	.08	.04	.39		.49	.27	2.96	
Step 2				.01				.06
Constant	3.34		15.77		5.06		30.28	
b ₁ LMX (E)	-.52	-.30	-2.73		.14	.10	.94	
b ₂ SLMX (S)	.10	.04	.42		.40	.22	2.23	
b ₃ S ²	.04	.01	.11		-.14	-.05	-.56	
b ₄ S x E	.04	.02	.19		-.36	-.19	-1.95	
b ₅ E ²	-.12	-.09	-.73		-.08	-.07	-.65	
Total R ²				.07				.21
<i>Congruence line (S = E)</i>								
Slope (b ₁ + b ₂)	-.42		-5.21		.54		6.69	
Curvature (b ₃ + b ₄ + b ₅)	-.04		-.95		-.58		-13.83	
<i>Incongruence line (S = -E)</i>								
Slope (b ₁ - b ₂)	-.62		-3.78		-.26		-1.59	
Curvature (b ₃ - b ₄ + b ₅)	-.12		-.70		.14		.82	

Note: Effects significant at $p < .05$ are bolded for ease of interpretation.

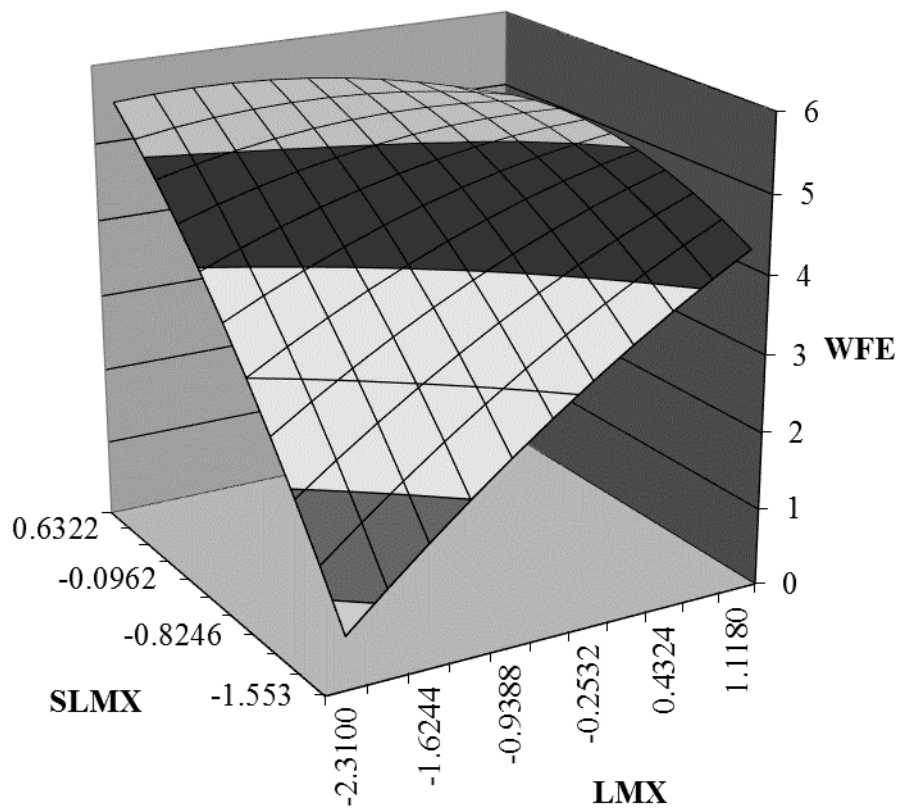

Figure 10. Response surface model of the congruence and incongruence effects of leader-member exchange with work-family enrichment.

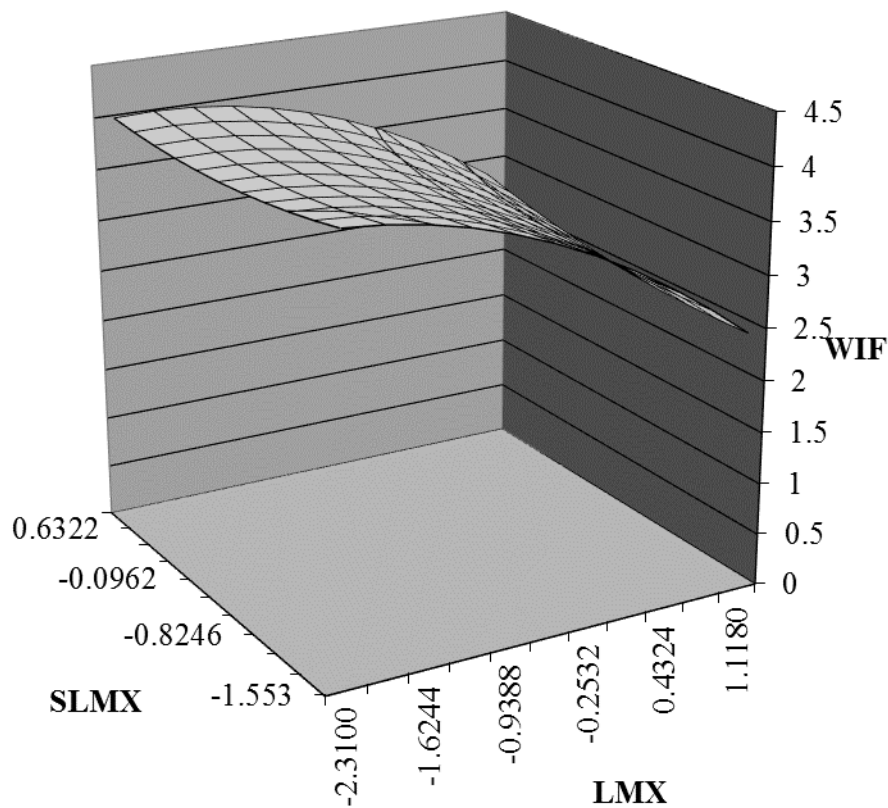

Figure 11. Response surface model of the congruence and incongruence effects of leader-member exchange with work interference with family.

Table 9.

Polynomial Regression of Flexibility I-Deals on LMX Congruence

Variable	Schedule Flexibility				Location Flexibility			
	B	β	t	R^2	B	β	t	R^2
Step 1				.06				.06
Constant	4.21		50.51		4.06		43.07	
LMX	.19	.18	1.83		.17	.14	1.47	
SLMX	.14	.10	1.06		.22	.15	1.44	
Step 2				.03				.03
Constant	4.04		29.71		3.97		25.82	
b ₁ LMX (E)	.26	.23	2.14		.26	.14	2.16	
b ₂ SLMX (S)	.19	.14	1.30		.18	.12	1.16	
b ₃ S ²	.23	.12	.77		-.03	-.01	-1.10	
b ₄ S x E	-.23	-.16	-1.71		-.25	-.15	-1.49	
b ₅ E ²	.16	.18	2.02		.22	.21	2.75	
Total R ²				.09				.09
<i>Congruence line (S = E)</i>								
Slope (b ₁ + b ₂)	.45		5.58		.44		5.45	
Curvature (b ₃ + b ₄ + b ₅)	.16		3.81		-.06		-1.43	
<i>Incongruence line (S = -E)</i>								
Slope (b ₁ - b ₂)	.07		.43		.08		.49	
Curvature (b ₃ - b ₄ + b ₅)	.62		3.61		.44		2.56	

Note: Effects significant at $p < .05$ are bolded for ease of interpretation.

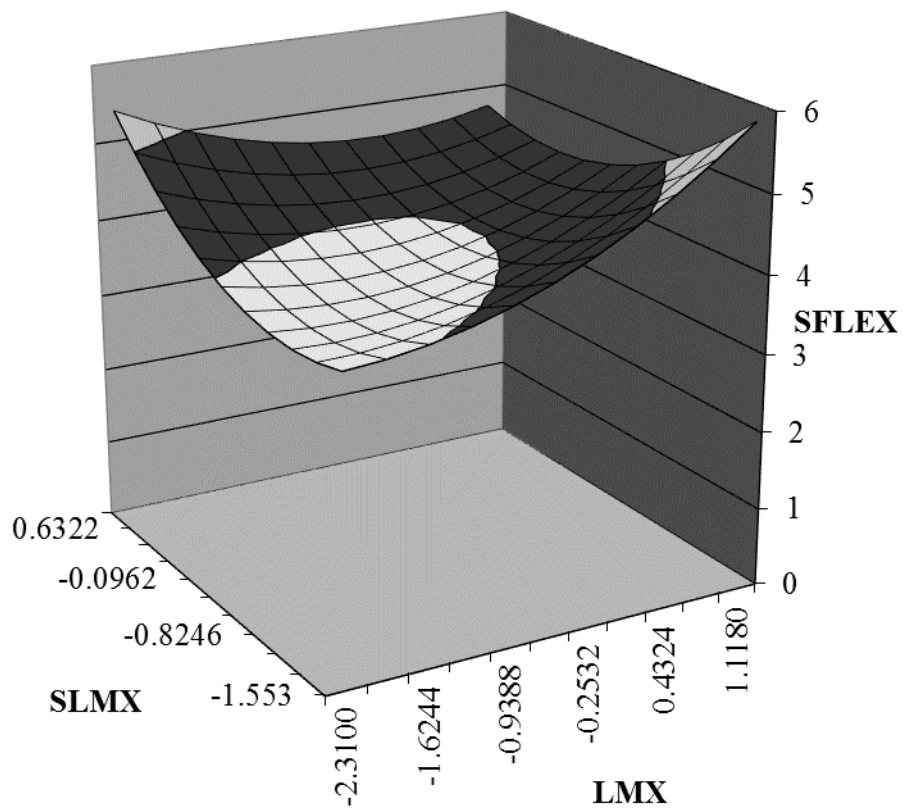

Figure 12. Response surface model of the congruence and incongruence effects of leader-member exchange with schedule flexibility i-deals.

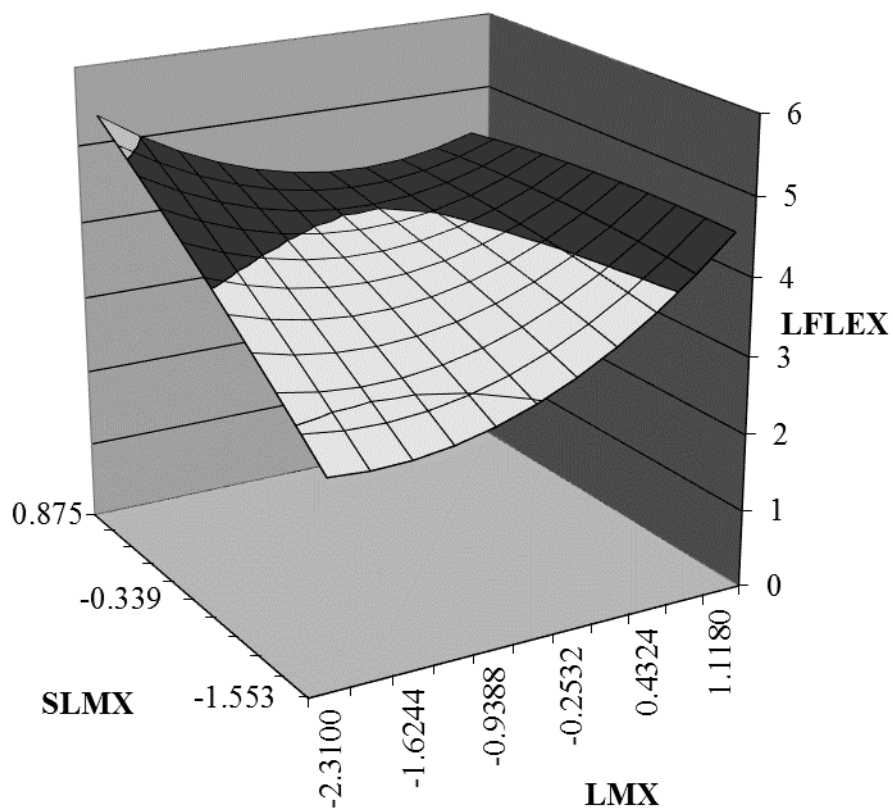

Figure 13. Response surface model of the congruence and incongruence effects of leader-member exchange with location flexibility i-deals.

Table 10.

Polynomial Regression of Developmental I-Deals on LMX Congruence

Variable	Task I-Deals				Career I-Deals			
	B	β	t	R^2	B	β	t	R^2
Step 1				.29				.25
Constant	3.78		57.32		3.60		50.88	
LMX	.36	.35	4.24		.44	.42	4.91	
SLMX	.34	.27	3.25		.17	.13	1.52	
Step 2				.02				.06
Constant	3.70		34.27		3.44		26.25	
b ₁ LMX (E)	.36	.36	4.00		.48	.46	3.99	
b ₂ SLMX (S)	.38	.30	4.11		.22	.16	1.54	
b ₃ S ²	.19	.11	1.12		.27	.15	1.18	
b ₄ S x E	-.21	-.16	-1.95		-.38	-.28	-3.11	
b ₅ E ²	.07	.08	.75		.17	.20	1.98	
Total R ²				.31				.30
<i>Congruence line (S = E)</i>								
Slope (b ₁ + b ₂)	.74		9.17		.70		8.68	
Curvature (b ₃ + b ₄ + b ₅)	.05		1.19		.06		1.43	
<i>Incongruence line (S = -E)</i>								
Slope (b ₁ - b ₂)	-.02		-.12		.26		1.59	
Curvature (b ₃ - b ₄ + b ₅)	.47		2.74		.82		4.78	

Note: Effects significant at $p < .05$ are bolded for ease of interpretation.

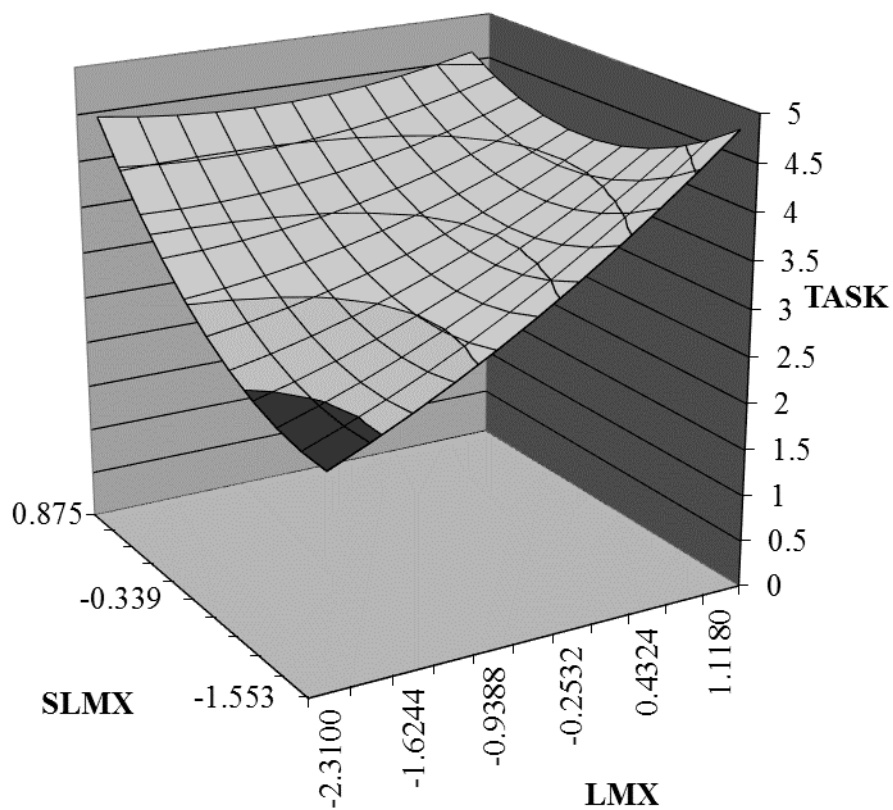

Figure 14. Response surface model of the congruence and incongruence effects of leader-member exchange with task i-deals.

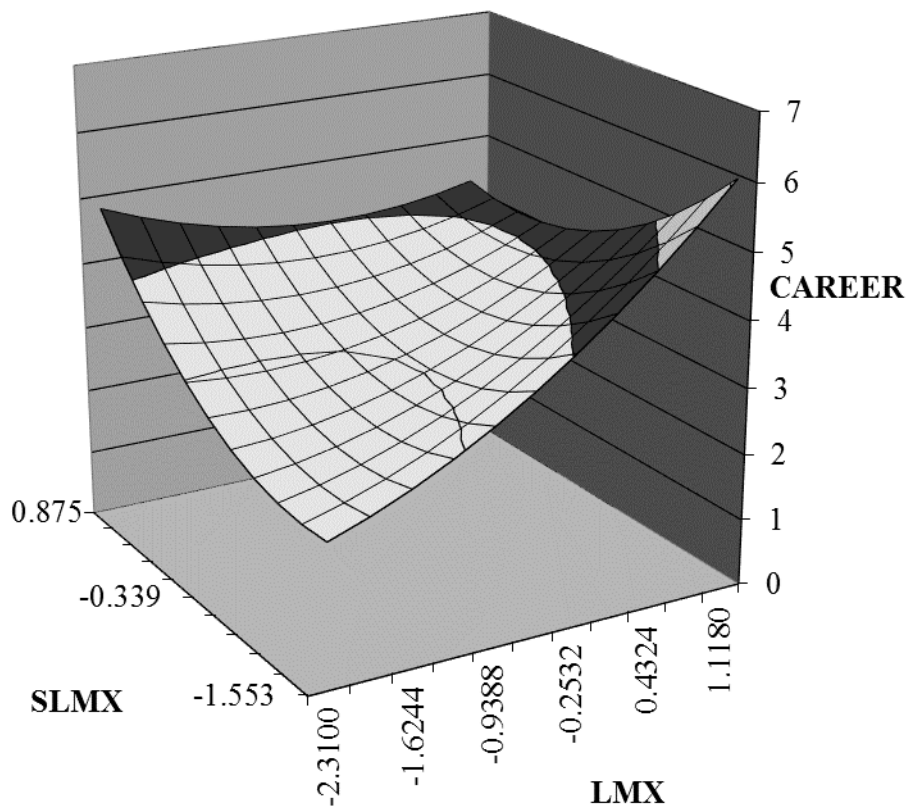

Figure 15. Response surface model of the congruence and incongruence effects of leader-member exchange with career development i-deals.

Additional Analyses

Revised conditional indirect effects models. Given that the proposed analyses were statistically underpowered, a series of post-hoc analyses were conducted to further test the model hypotheses. Four independent moderated mediation models were conducted to examine the conditional indirect effects of LMX on work-family experiences at different levels of SLMX for each of the four types of idiosyncratic deals. Conducting the analyses in this way conserves variance in WIF and WFE that would otherwise be shared amongst the four types of i-deals (Cohen et al., 2003; Kline, 2011). Tables 11 and 12 depict the revised conditional indirect effects models for WFE and WIF, respectively.

SLMX did not moderate the indirect effect from LMX to WIF via any form of idiosyncratic deal. In the initial set of analyses, schedule flexibility i-deals mediated the relationship between LMX and WIF only at low levels of SLMX. However, without the other three types of idiosyncratic deals included in the model, this indirect effect became non-significant at every level of SLMX. With respect to WFE, the conditional indirect effect for task i-deals was statistically significant at low, $b = .243$ (.015, .470), $SE = .116$, and mean levels of SLMX, $b = .179$ (.024, .335), $SE = .079$, but not at high SLMX, $b = .116$ (-.043, .274), $SE = .081$. Furthermore, the conditional indirect effect for career development i-deals was statistically significant at low, $b = .267$ (.046, .487), $SE = .112$, and mean levels of SLMX, $b = .178$ (.024, .329), $SE = .077$, but not at high SLMX, $b = .089$ (-.043, .258), $SE = .086$.

Indirect effects model from SLMX. Although not directly hypothesized, the model indirect effects were also examined with SLMX as the antecedent and with LMX excluded from the model ($n = 133$). In this model, SLMX was significantly related to career development, $\beta = .324$, $p < .001$, task, $\beta = .434$, $p < .001$, location flexibility, $\beta = .203$, $p = .035$, and schedule flexibility,

$\beta = .183, p = .036$. WIF was negatively related to schedule flexibility i-deals, $\beta = -.389, p < .001$, and WFE was positively related to task i-deals, $\beta = .264, p = .045$. Since the direct path between SLMX and WFE was positive and significant, $\beta = .185, p = .019$, task i-deals were considered to partially mediate the relationship between SLMX and WFE, $\beta = .125, p = .046$. Neither the indirect paths nor the direct path between SLMX and WIF were not statistically significant.

Table 11.

Revised Conditional Indirect Effects of LMX on WFE at Low, Mean, and High Levels of SLMX

Model	Level	Direct Effect	Indirect Effect	Total Effects
Task I-Deals	SLMX _{Low}	.19	.24*	.44*
	SLMX _{Mean}	.19	.18*	.37*
	SLMX _{High}	.19	.12	.31
Career I-Deals	SLMX _{Low}	.23	.27*	.50**
	SLMX _{Mean}	.23	.18*	.41*
	SLMX _{High}	.23	.09	.32
Schedule I-Deals	SLMX _{Low}	.38*	.07	.45**
	SLMX _{Mean}	.38*	.05	.43*
	SLMX _{High}	.38*	.03	.41*
Location I-Deals	SLMX _{Low}	.40**	.05	.45**
	SLMX _{Mean}	.40**	.03	.43**
	SLMX _{High}	.40**	.01	.41*

Note: SLMX was -0.71 (1 SD below the mean) and 0.71 (1 SD above the mean) for low and high levels, respectively.

* $p < .05$, ** $p < .01$, *** $p < .001$.

Table 12.

Revised Conditional Indirect Effects of LMX on WIF at Low, Mean, and High Levels of SLMX

Model	Level	Direct Effect	Indirect Effect	Total Effects
Task I-Deals	SLMX _{Low}	-.42**	-.00	-.42**
	SLMX _{Mean}	-.42**	-.00	-.42**
	SLMX _{High}	-.42**	-.00	-.42**
Career I-Deals	SLMX _{Low}	-.36*	-.07	-.43**
	SLMX _{Mean}	-.36*	-.04	-.41**
	SLMX _{High}	-.36*	-.02	-.39**
Schedule I-Deals	SLMX _{Low}	-.33**	-.09	-.42**
	SLMX _{Mean}	-.33**	-.07	-.40**
	SLMX _{High}	-.33**	-.04	-.37**
Location I-Deals	SLMX _{Low}	-.39**	-.03	-.42**
	SLMX _{Mean}	-.39**	-.02	-.41**
	SLMX _{High}	-.39**	-.01	-.39**

Note: SLMX was -0.71 (1 SD below the mean) and 0.71 (1 SD above the mean) for low and high levels, respectively.

* $p < .05$, ** $p < .01$, *** $p < .001$.

Qualitative analysis of i-deals. Based on the recommendation of a committee member, an optional, open-ended question was included in the survey in an attempt to gain a deeper understanding of employees' experiences negotiating for idiosyncratic deals. Specifically, employees were asked, "Have you ever attempted to negotiate for a personalized or unique (a) career development opportunity, or (b) accommodation for improved work-family balance, but were unsuccessful? If so, please describe your situation."

In total, 74 employees responded to this question in some way. Of these responses, 52 employees described never experiencing an unsuccessful negotiation regarding specialized work arrangements. Unfortunately a large portion (82.7%) of these respondents replied with answers such as, 'no,' or some variation of, 'have never been unsuccessful in negotiations,' with no further detail. Of the 9 employees who provided context to their answers, 7 respondents specifically described that specialized role negotiations are encouraged at this organization:

"No, (this organization) has always accommodated my reasonable requests."

"No. But I have been successful in negotiating outside employment, teleworking, and the specific jobs and projects I've been assigned to."

"No. I have had a lot of latitude for career choices made and work hours. Growth details are always encouraged if you take initiative."

The other 2 respondents seemed to emphasize that role negotiations are welcomed by the organization, but that generally negotiating for opportunities in one life role may impact the other:

"No. In my experience, work-family balance comes first if you want it. Management is accommodating of your personal needs. That does not mean it doesn't come with a cost; your career may suffer due to passing up on opportunities (and thus being captured by others)."

"No; you can negotiate your schedule to be very flexible, but there is still too much work to do!"

On the other hand, 22 participants responded that they had been unsuccessful in negotiating specialized work opportunities. All of the respondents described situations in which they were unsuccessful at negotiating developmental i-deals. 10 respondents specifically described unsuccessful negotiations with their immediate supervisor related to career advancement, training opportunities, or increased responsibility for tasks and projects:

“Yes, multiple times. I have frequently requested to take on tasks in my branch. Sometimes this is successful, but other times it's a struggle to get the authority, autonomy, tools, or training/mentoring to actually do the job; other times the job is only grudgingly delegated and the decision is so late that it makes the job harder to do; and other times (often) the work is delegated but the credit isn't, so it doesn't contribute as much to my career development.”

“Yes, I told my branch head that I would like to work in a multidisciplinary leadership role that utilizes my diverse scientific background. I have repeatedly requested but never received any such work.”

“I have been asking my supervisor what I can do to be a better candidate for promotion for three years. I have been told that I have improved in the specified dimensions and that I am a very good candidate for promotion. I have provided all the materials requested by my supervisor for the promotion application. However, I continue to need to remind my supervisor to submit the paperwork.”

“Yes - (1) Training class on international project development, (2) professional conference – both shut down due to my manager's discretion.”

As expected, respondents generally reported their partner in these unsuccessful negotiation attempts to be their direct supervisor (i.e., branch manager). However, a number of respondents also described that their role negotiation was unsuccessful despite their immediate supervisor's support in accommodating their request:

“Yes, for career reasons I attempted to get a detail at (another location). My branch management was extremely supportive and I had several meetings with people at (other location), but I ran into several hurdles with (Human Resources) and senior leadership.”

“My team leader / project manager has responded extremely negatively to (personal research), career development, and technical breadth activities. Branch management was supportive of these activities but did little to help resolve the issue with my project manager.”

“Yes, I have tried several times to negotiate for opportunities to advance my career and I have been unsuccessful. Within the center, senior leadership has chosen to support other

disciplines within the organization. Senior leadership has chosen to support a handful of individuals in leadership development and with leadership positions. Even though my manager pushes for me, (my organization) is very poor including mid-level people in strategic planning and in leadership or succession development. Consequently, there is a dependence on only a few individuals and very little sharing with the many talented people available to provide ideas and leadership.”

Finally, although a handful of respondents reported issues with work-family balance as a result of unsuccessful negotiation of developmental i-deals, none of the respondents reported unsuccessfully negotiating a flexibility i-deal:

“When I interviewed for this position I was encouraged to continue my graduate degree and would receive support. Despite my best efforts, this did not end up happening resulting in a high degree of personal strain and a severe breach of trust.”

“Advancement (at this organization) means increasing field work and busy schedule (which) creates the situation where work-family balance is jeopardized. Project management has demonstrated a willingness to sacrifice work-family balance in the name of (career) opportunities. This is justified by claiming a perceived majority of those are willing to make the sacrifice, and dissenting individuals in the minority are pressured to conform. Some branch managers appear to understand that this sort of mentality is unsustainable and demoralizing for the workforce. It is unclear if this is understood by senior leadership – they have been overheard suggesting that this ‘(work) trumps family’ mentality is just another tough decision that needs to be made.”

One respondent described that s/he has specifically not negotiated for flexibility outside of the formal work-family policies of the organization:

“Typically I take it that work-family balance needs to be achieved within the existing attendance and leave policies, so I do not "negotiate" outside that framework.”

CHAPTER IV

DISCUSSION

The aim of this study was to address prominent gaps in the research linking leadership theory to the work-family interface by examining relationships between LMX, idiosyncratic deals, and work-family conflict and enrichment. This was accomplished by collecting matched survey responses from supervisor-subordinate dyads and testing a moderated mediation model in which supervisor-rated LMX moderated the indirect effect from LMX to work-family outcomes via i-deals. Although the majority of the variables of interest were significantly related and in the expected directions, the moderated mediation hypotheses were not supported. Nonetheless, the study hypothesis tests and supplementary analyses have important theoretical and practical implications and should serve to inform future research in this area. In the sections that follow, I describe the implications of this study's findings, discuss study limitations, and propose future research directions related to the current work.

Hypothesis 1 sought to replicate research suggesting WIF and WFE share a negative relationship. Results supported this hypothesis as zero-order correlations and model parameter estimates both demonstrated a significant negative relationship. The next set of hypotheses examined the relationships between LMX, SLMX, and work-family outcomes. Both members' assessments of LMX were expected to be negatively linked to WIF and positively related to WFE. Zero-order correlations demonstrated that LMX was negatively related to WIF and positively related to WFE, however, SLMX was significantly related only to WFE. Only two of these relationships remained statistically significant in the full model; LMX and WIF shared a significant negative relationship and SLMX and WFE were positively related. The relationship between SLMX and WIF was non-significant in both models. After controlling for between-

supervisor effects, the interaction between LMX and SLMX was negative and statistically significant for WFE, but was not significantly related to WIF. Although SLMX did not exhibit the hypothesized enhancement effect on the LMX-WFE relationship, a plot of the simple slopes for the LMX-SLMX interaction suggested that WFE is highest when one or both members of the supervisor-subordinate dyad perceived high LMX.

The next set of hypotheses examined the relationships between i-deals and work-family experiences. As expected, zero-order correlations demonstrated schedule flexibility i-deals to be negatively related to WIF and positively related to WFE. However, in the path model, the link between schedule flexibility i-deals and WFE became non-significant. Location flexibility i-deals were negatively correlated to WIF, but were not significantly related to either work-family experience in the path model. Zero-order correlations showed both task and career development i-deals to be positively related to WFE, however the path from career i-deals to WFE became non-significant in the full model. Although not directly hypothesized, career i-deals were significantly and negatively correlated with WIF. Neither form of developmental i-deal was significantly related to WIF in the full model.

Zero-order correlations demonstrated both LMX and SLMX to be positively related to each of the four types of i-deals. In the path model, SLMX was significantly related only to task i-deals, and LMX was related to schedule flexibility, task, and career development i-deals. Only one hypothesis positioning idiosyncratic deals as mediators of the relationships between LMX and work-family experiences was supported in the full model. The indirect effect from LMX to WFE via task i-deals was positive and significant. To conserve statistical power, indirect effects were also examined in a model that excluded SLMX and the interaction terms as independent variables. Task i-deals remained the only significant mediator in the LMX – WFE relationship,

and the indirect effect from LMX to WIF via schedule flexibility i-deals became statistically significant in this model. A final set of supplementary analyses related to these hypotheses showed the indirect effects from SLMX to WFE via task i-deals to be the only statistically significant mediator.

Next, I examined the interactive effects of LMX and SLMX on i-deals. The addition of the interaction term contributed significant variance only to the career development i-deals model, and the regression coefficient for the interaction was in the negative direction. Simple slopes revealed that the positive relationship between LMX and career i-deals was stronger at lower, rather than higher, levels of SLMX. The hypotheses related to the moderated mediation model were unsupported. The positive indirect effect from LMX to WFE via task i-deals and the negative relationship between LMX and WIF via schedule flexibility i-deals were only statistically significant at lower levels of SLMX. To conserve explained variance in the dependent variables, four separate conditional indirect effects models were analyzed for each of the i-deal types. In these models, i-deals did not mediate the relationship between LMX and WIF at any level of SLMX. The direct path between LMX and WIF was negative and statistically significant. However, career development and task i-deals each mediated the LMX – WFE relationship at low and mean levels of SLMX.

Finally, I examined the effects of LMX congruence on idiosyncratic deals and work-family experiences. The addition of the interaction and polynomial terms contributed significant unique variance to the career development i-deals and WFE models. Examination of the polynomial regression coefficients and the response surfaces indicated that a LMX incongruence effect was detected for career development i-deals, such that the dependent variable was highest when supervisor and subordinate perceptions of LMX were incongruent, particularly when the

subordinate perceived higher LMX. Although a congruence effect was not detected for WFE, the response surface clearly indicates that WFE is highest when one or both dyad members perceive higher LMX quality.

This study makes a number of contributions to the leadership and work-family literatures. First, this study is one of only a few to empirically examine mediators of the relationship between LMX and employees' work-family experiences, and is the first to empirically position i-deals as a LMX-generated resource germane to work-family management. Although indirect effects were not significant in the full model, follow-up analyses conducted to conserve statistical power indicated that task and career development i-deals mediate the relationship between LMX and WFE. These findings are aligned with LMX theory and research. Supervisors and subordinates in higher quality LMX relationships develop an expectation of mutual benefit and resource exchange (Gerstner & Day, 1997). As a result of mutual professional respect and commitment, the subordinate is productive and loyal to the supervisor and the supervisor reciprocates by providing resources, including negotiating latitude, which can be used to modify the subordinate's work role to better align with his or her work-family needs. More specifically, the current research suggests that higher-LMX subordinates are more likely to negotiate for and receive specialized work arrangements related to professional development, and through these enhanced work roles, are afforded the opportunity to develop resources spillover to enhance their family role. This finding is well-aligned with the expansionist view of work-family management, which posits that that multiple role involvement can facilitate resource generation and result in beneficial outcomes (Greenhaus & Parasuraman, 1999; Marks, 1977). Through their amplified work role, subordinates may develop skills (e.g., coping, negotiation, and conflict management),

perspectives (e.g., empathy, perspective-taking), and other resources that can directly be applied to enhance performance at home (i.e., higher WFE).

Very importantly, as expected but not directly hypothesized, the direct paths between developmental i-deals and WIF were non-significant in the full model, indicating that even after controlling for flexibility i-deals, WIF was not adversely impacted by the increased work role involvement inherent in task or career development i-deals. This research proposed that an employee would likely only negotiate for a developmental i-deal if it aligned with his or her salient goals at that particular time. However, this study's finding conflicts with one existing research study and aligns with another. Although Hornung et al. (2011) did not find a statistically significant relationship between developmental i-deals and WIF in two samples of German physicians, Hornung et al. (2008) showed developmental i-deals to positively relate to work-family conflict when holding the effects of flexibility i-deals constant. An investigation of the 2008 study revealed that the set of predictors, including both types of i-deals, contributed only 3 percent variance to the prediction of WIF. Furthermore, the descriptive statistics for this study suggest that developmental i-deals may not have been relevant to the vast majority of the sample. Using a 5-point Likert-type scale with higher scores indicating that their current jobs consisted of i-deals to a greater extent, the descriptive statistics for developmental i-deals ($M = 1.64$, $SD = 0.75$) suggest that the developmental i-deals data is positively skewed, and it would require more than 1 SD above the mean to capture an individual who has negotiated for a developmental i-deal to some extent.

Surprisingly, the indirect effect hypotheses concerning the relationship between LMX and work-family experiences via flexibility i-deals were not supported. It was expected that flexibility i-deals may be negotiated to help redesign unfavorable work conditions to be more

accommodating of work and family. Although zero-order correlations suggested that location flexibility i-deals were positively related to LMX and negatively related to WIF, in the full model, flexibility i-deals were not significantly related to any other variables. In retrospect, this finding may be due to the organization from which the sample was drawn from. First, this organization has a liberal telecommuting option that affords all employees the opportunity to work from a convenient location. Due to this formal family-friendly policy, it seems likely that employees in this organization may be less reliant on their immediate supervisor to authorize a specialized work arrangement related to location flexibility. Conversely, because the telework policy is well-advertised in this organization, it may be that supervisors perceive less decision-making power in negotiations related to location flexibility, thereby granting these requests to numerous employees regardless of LMX quality. Furthermore, although the direct path from location flexibility i-deals to WIF was non-significant in the full model, the parameter estimate was in the positive direction. This finding is somewhat aligned with research providing conflicting findings related to the work-family benefits associated with telework. While telework is regularly implemented to balance the employee's work and family demands (Sullivan & Lewis, 2001), and generally shows small, but negative relationships with WIF, it may also contribute to the blurring of family and work role boundaries (Hill et al., 1996; Mustafa, 2010), resulting in increased work-family conflict (Lapierre & Allen, 2006). Work-family researchers have increasingly incorporated measures of boundary management and integration-segmentation preferences to better understand differences in this relationship (e.g., Paustian-Underdahl, Halbesleben, Carlson, & Kacmar, 2013; Michel & Clark, 2013). Individuals who prefer to integrate life roles have very permeable role boundaries, and prefer to blend the experiences of life domains into a single holistic experience (Ashforth, Kreiner, & Fugate, 2000). Conversely,

individuals who prefer to segment life roles purposefully erect physical, emotional, or cognitive barriers to separate the primary domains of their lives (Ashforth, et al., 2000). Going one step further, future research may benefit from examining of ‘who’ negotiates for location flexibility i-deals. It seems likely that employees who prefer integration may be more expected to not only initiate i-deal negotiations for location flexibility, but may also benefit more from such an arrangement (i.e., lower WIF).

The full model showed LMX to be positively related to schedule flexibility i-deals, and demonstrated schedule flexibility i-deals to be negatively related to WIF. However, the indirect effect from LMX to WIF via schedule flexibility i-deals was not statistically significant. Although the inability to detect this indirect effect in the full model was likely due to low statistical power, supplementary analyses excluding SLMX suggested the relationship between LMX and WIF via schedule flexibility i-deals was negative and statistically significant. In line with LMX theory, this finding suggests that higher-LMX employees may be afforded more negotiating latitude through which they can modify work schedules to accommodate unique circumstances, ultimately ameliorating WIF. It is important to note that the direct path between LMX and WIF remained statistically significant and in the negative direction in both the full and trimmed models, indicating that while schedule flexibility i-deals may be one LMX-generated resource that can serve to optimize employees’ work-family experiences, there are likely many others, as well. Future research should continue to explore additional mechanisms by which higher-LMX is linked to lower WIF, including empirical examinations of resources known to be exchanged in high-LMX relationships. For example, Graen and Scandura (1987) demonstrated that supervisors provide more support to their higher-LMX subordinates. In the work-family literature, it is well understood that employees who perceive greater supervisor support are better

able to manage and cope with their competing work-family demands. Therefore, it makes sense to position family-specific supervisor support as a mechanism by which LMX is linked to lower WIF. Leadership and work-family scholars should be allies in this continued effort to link these two areas of research, as many additional LMX-generated resources may also be germane to work-family (e.g., more frequent communication may provide greater opportunity to build awareness of subordinates' work-family needs).

Furthermore, this research makes a meaningful contribution to the work-family literature by incorporating the supervisor's assessment of LMX. Given that i-deals are inherently mutually beneficial to both dyad members and it is the supervisor who is generally responsible for authorizing i-deal requests, it was surprising to find that SLMX was only related to task i-deals in the full model. However, follow-up analyses suggest that inability to detect this effect may be due to common method variance. Due to organizational constraints, subordinates responded to items related to LMX, i-deals, WIF, and WFE at a single time point. Cross-sectional, self-report data is particularly prone to common method variance, which inflates observed relationships between constructs (Podsakoff, MacKenzie, Lee, & Podsakoff, 2003). As such, artifactual covariance attributable to the same source responding to all measures at the same time likely accounts for a significant portion of variance above and beyond the content of the constructs themselves (Podsakoff et al., 2003; Podsakoff, MacKenzie, & Podsakoff, 2012). As a result, a revised model excluding LMX was tested to examine the indirect effects from SLMX to work-family experiences via i-deals. In this model, after controlling for between-supervisor effects, SLMX was significantly related to all four types of i-deals, and task i-deals partially mediated the relationship between SLMX and WFE.

The ability to detect relationships between supervisor-rated LMX and subordinate-rated task i-deals and WFE in the full model demonstrates the importance of SLMX in the resource exchange process. After controlling for between-supervisor effects, and holding all other variables (i.e., LMX, career, location, and schedule i-deals) in the model constant, the direct path between SLMX and WFE was positive and statistically significant. Inherent in LMX theory is the concept that a supervisor provides higher-LMX subordinates with greater access to resources in exchange for their productivity and contributions to the supervisor-subordinate relationship (Gerstner & Day, 1997; Liden & Maslyn, 1998). Given that it is actions by the supervisor that theoretically serve to increase work-family enrichment (Litano et al., 2016), this study makes an important contribution in that it demonstrates the importance of the supervisor's perspective of LMX quality in work-family resource allocation.

In addition, work-family researchers have argued that LMX might be a 'double-edged' sword with potentially negative outcomes for employees attempting to manage work-family demands (Bernas & Major, 2000; Chen, 2013). For example, it has been suggested that leaders may rely more heavily on high-LMX subordinates, who may then become overburdened with greater work responsibility that interferes with their family life. Results from this study, however, suggest that even after controlling for subordinate-rated LMX and flexibility i-deals, SLMX was not significantly related to WIF.

Perhaps most surprising was the finding that SLMX moderated the indirect effects from LMX to work-family experiences via i-deals in the opposite direction than originally proposed. Whereas SLMX was proposed to enhance these relationships, results suggested that the indirect effects from LMX to WFE via task i-deals, and from LMX to WIF via schedule flexibility i-deals, were only statistically significant at low levels of SLMX. Supplementary analyses

conducted to conserve statistical power suggested that career development and task i-deals mediate the LMX – WFE relationship at mean and low levels of SLMX, but not at higher levels, and that i-deals did not mediate the relationship between LMX and WIF at any level of SLMX. Given that high-LMX subordinates are afforded greater access to resources, it seems that these employees may be offered, or may possess more leverage to negotiate for, resources that are *more* applicable to the work-family interface than i-deals. For example, supervisor support for work-family has consistently been recognized as one of the most consistent predictors of reduced work-family conflict (Kossek et al., 2011; Hammer et al., 2009). Given the importance of supervisor work-family support in ameliorating WIF, it seems likely that this might be a more relevant and impactful work-family resource acquired via high LMX. Using multi-wave data, Litano and Major (2015) recently showed that FSSB completely mediates the relationship between LMX and WIF, but that the relationship between FSSB and WFE became non-significant with LMX in the model. The current research could contribute to a clearer picture of how this process works. For example, those lower-LMX subordinates who are less likely to receive family-support from their supervisor may be more likely to experience a work role that is incongruent with their salient work-family needs, ultimately requiring them to negotiate for specialized work arrangements.

Another possible explanation for this finding is that supervisors may use i-deals as a mechanism for initiating or improving the LMX relationship. Although Hornung et al. (2009) found that supervisors who authorized employee-initiated i-deal requests anticipated increased performance and motivation in exchange for granting developmental i-deals, and expected subordinates' work-family balance to be enhanced via flexibility i-deals, such arrangements can be proposed by either the employee or employer. Theoretically it makes sense that supervisors

may propose i-deals to higher-LMX subordinates as a reward to reinforce positive work behaviors, but it seems possible that i-deals could also be used by supervisors to initiate the social exchange process with low-LMX employees.

Such findings may actually align with recent research suggesting that i-deals may be a substitute for LMX quality. Research conducted by Anand, Vidyarthi, Liden, and Rousseau (2010) suggested that LMX moderated the relationship between developmental i-deals and organizational citizenship behaviors such that the links between i-deals and OCBs targeted at both one's organization and other organizational members were stronger for lower-LMX employees. Ultimately, these researchers suggested that it is possible that i-deals can compensate for low-quality LMX, and that higher-LMX employees may not require the negotiation of i-deals to optimize their work role.

Finally, this research sought to mirror trends in the leadership literature by examining the effects of LMX congruence on i-deals and work-family experiences in an exploratory manner. The addition of polynomial terms contributed trivial variance to the prediction of WIF, task i-deals, and both forms of flexibility i-deals. However, an interaction was detected for WFE, such that WFE was highest when at least one of the dyad members perceived LMX quality to be high. Clearly, in the low-low LMX conditions, subordinates seem unlikely to be satisfied with their limited access to resources, and supervisors may be less likely to afford resources to such employees, whereas the opposite holds true for the high-high LMX conditions. However, it is interesting to note that WFE remains high when only the supervisor or subordinate perceive high-LMX. One possible explanation for this finding is that the supervisor appraises LMX to be high due to the subordinate's valuable contributions to the LMX relationship and for that reason makes resources more accessible to this employee. However, the subordinate may perceive low-

LMX if the supervisor is reciprocating the subordinate's contributions to the LMX relationship with resources the employee perceives to be irrelevant or less valuable. Those resources may still spillover to positively impact family role performance despite negative attributions of the supervisor-subordinate relationship. Relatedly, a study by Zhou and Schriesheim (2010) showed that both parties tend to perceive different aspects of the supervisor-subordinate relationship as most important. Supervisors tend to emphasize task-related items while subordinates placed a greater importance on social features of the relationship. Thus, the degree to which supervisors and subordinates place greater importance on different aspects of the relationship can lead to divergence in their LMX assessments. Although WFE may be highest when at least one dyad member perceives high-LMX, it seems likely that the resources exchanged in such relationships may vary. The work-family literature would benefit from a deeper understanding of the LMX-generated resources most likely to result in higher WFE, and whether or not the type of WFE (i.e., affect, capital, development) varies depending on which party rates LMX quality as higher.

Finally, an (in)congruence effect was detected for career development i-deals. When LMX assessments were congruent, career i-deals increased at higher levels of LMX quality. However, the positive curvature of the incongruence line suggested that career i-deals are generally higher when supervisor and subordinate perceptions of LMX were incongruent. In the cases of incongruence, career development i-deals were highest when the subordinate perceived higher LMX. In general, while this finding aligns with recent leadership research suggesting that LMX (in)congruence is meaningful construct that explains unique variance above and beyond supervisor and subordinate ratings alone (e.g., Matta et al., 2015; Schriesheim et al., 2011), the results also conflict with recent work on LMX congruence. Specifically, Matta et al. (2015) showed that employee engagement, and resulting organizational citizenship behaviors, were

highest when LMX was in agreement irrespective of LMX quality. That is, subordinate-rated engagement was highest when both dyad members rated LMX similarly, even if the assessed quality was low. Matta et al. (2015) noted that their findings were counterintuitive, such that role theory (Kahn, et al., 1964) would suggest that the subordinate's perception of LMX would likely be more strongly associated with work engagement given that both assessments are related to one's role as employee. In the current study, career i-deals were higher in all situations except when the two parties were in agreement that LMX was lower. In all other instances, either the supervisor may be more willing to offer those subordinates he or she perceives to be higher-LMX subordinates personalized opportunities for career development, or the subordinate might be more comfortable initiating negotiations for career i-deals with a supervisor he or she perceives to be higher LMX. The question then becomes, why do supervisors authorize career i-deals for low-LMX subordinates (who perceive LMX quality to be higher)? One possible reason is that supervisors offer or authorize certain types of i-deals as a way to initiate the LMX relationship. Follow-up studies using longitudinal or cross-lagged designs may help to better understand the directionality of this relationship, and qualitative research methods, such as interviews, focus groups, or ethnography, may help to provide the detail and context to better understand the i-deal negotiation process.

Limitations and Strengths

The current research has several strengths. First, a strength of this study lies in the sampling of employees in an organizational setting. Sampling working adults within a single organization controls for the impact of organizational culture and formal family-friendly policies on work-family outcomes. However, this approach can also be regarded as a weakness. For one, the organization sampled is a government organization, which generally restricts average work

hours to 40 per week and offers policies that are considered more family-friendly than those generally offer by private US organizations. On top of that, this organization has been rated as one of the most family-friendly federal organizations to work for in the federal government for the past six years (Best Places to Work, 2016). Supervisors and other organizational members are not only more likely to demonstrate empathy and sensitivity to employees' work-family needs in the presence of a supportive work-family culture (Thompson, et al., 1999), but research suggests that work-family culture may influence WIF via LMX (Major et al., 2008). These studies suggest that leaders in the current organization may naturally be more receptive to employees' work-family requests. Future research would benefit from replications of this study in private, white-collar US corporations.

In addition, the use of multi-source data (supervisor and subordinate reports) is a notable strength of this study as such an approach helps to mitigate the over-inflation of predictor-criterion relationships (Podsakoff et al., 2003; Spector, 2006). However, common method bias may still be a concern given that the subordinates responded to all of the study measures at a single time point (Podsakoff et al., 2003). Although selective perception is a concern whenever self-report data are used (Podsakoff & MacKenzie, 2012), aside from LMX, the outcomes of interest in this study can only be measured using participant self-report. More specifically, the measures of WIF and WFE are intended to describe employees' perceptions of these constructs. Furthermore, the cross-sectional nature of this study is not permissive of causality inferences (Cohen et al., 2003). Theoretically, subordinates engaged in higher-quality LMX relationships should possess greater negotiating latitude (Dienesch & Liden, 1986), allowing them to modify their work role to better align with their salient work-family needs. However, it is also possible that i-deals are used by supervisors to initiate the social exchange process with subordinates,

thereby positioning i-deals as antecedent to LMX. To reaffirm these assertions, future research would benefit from the use of longitudinal and/or cross-lagged designs.

The final strength of the study is in its analytic approach. This study employed confirmatory factor analysis, path analysis, and polynomial regression with response surface methodology while controlling for between-supervisor effects to unpack the relationship between supervisor and subordinate perceptions of LMX and related outcomes. The CFA approach allowed for the estimation of error in the measurement model and the path analysis approach allows for testing of multiple dependent variables, multiple independent variables, and the interplay between these variables simultaneously (Schumacker & Lomax, 2004). This study also borrows an analytic approach from the leadership literature to better understand the work-family effects of LMX (in)congruence. Despite these advantages, the study was statistically underpowered. Despite my best efforts to advertise the opportunity to participate in the current research study, I was only able to recruit 133 matched supervisor-subordinate dyads. A larger sample size would permit stronger analytical approaches to be used, including fully latent structural equation modeling (SEM) which allows for the estimation of error in both the measurement and structural models.

Future Research Directions

In addition to those described in the previous sections, study findings point to several directions for future research. First, leadership and work-family research would benefit from a deeper investigation into the relationship between SLMX and WFE. Rooted in resource-based theories (COR; JD-R), it is unsurprising to find that SLMX is positively related to WFE above and beyond i-deals. However, it is noteworthy that the relationship between LMX and WFE became non-significant with SLMX in the model. Possible explanations for these findings were

discussed in greater detail in an earlier section, but scholars seeking to build upon this finding are encouraged to further consider resources not specific to work-family that may be exchanged through higher-quality LMX relationships and have positive work-family implications. In particular, psychological (e.g., positive psychological capital) and physical (e.g., energy) resources that are stimulated through motivating work relationships (i.e., LMX) may enhance WFE while simultaneously buffering the negative effects of work demands. Future research examining the importance of leadership for work-family should focus not only on reducing interrole conflict, but also to better understand how one's life roles can benefit one another.

Second, the qualitative analysis of subordinate responses regarding unsuccessful i-deal negotiations suggests that interested researchers should broaden their scope to consider other negotiation partners. Nearly half of the respondents described their immediate supervisor as the negotiation partner in their failed attempt. However participants also described situations in which they unsuccessfully negotiated for i-deals despite their supervisors' support. More specifically, their negotiation partners in these unsuccessful attempts included project managers, team leads, senior leadership, and human resources. Therefore, while one's immediate supervisor may represent the most common negotiating partner for i-deals, researchers should consider the influence of other organizational agents. Though not directly related, Vidyanthi et al. (2014) examined the effects of congruence between consultants' perception of LMX with their immediate supervisor in their home organization and their perceptions of LMX with their immediate supervisor at the client location and the resulting impact on subordinate outcomes. Results suggested that both LMX relationships were positively related to job satisfaction and negatively related to voluntary turnover, and that congruence in these LMX relationships contributed unique variance in the outcomes. However, when incongruent, the LMX relationship

with the supervisor in their home organization had a stronger effect on subordinate outcomes. In matrix organizations that require employees to report to multiple supervisors (e.g., the current organization), researchers should consider whether the LMX quality of one supervisor-subordinate relationship (e.g., project manager) acts as a boundary condition for resource exchange and/or i-deal negotiation in another (e.g., branch manager).

Future research can build on this study's findings by incorporating multi-level study designs. More specifically, since both LMX quality and idiosyncratic deals are unique and vary among a supervisor's subordinates, an examination of the effects of LMX differentiation would be a welcome addition. LMX differentiation is defined as the extent to which LMX quality is perceived by subordinates to vary within their team or workgroup (Henderson, Liden, Glibkowski, & Chaudhry, 2009). When LMX differentiation is higher, subordinates are less likely to experience equal access to the leader's resources (e.g., negotiating latitude; Hooper & Martin, 2008), likely impacting the extent to which i-deals are authorized. Furthermore, when i-deals are authorized in the context of a highly-differentiated workgroup, the i-deal may have a greater impact on its intended outcomes. For example in the last month, Liao, Wayne, Liden, and Meuser (2016) published a moderated mediation model examining the indirect effects of i-deals on subordinate outcomes (i.e., job satisfaction, helping behaviors, in-role performance) via supervisory procedural justice and LMX quality at different levels of LMX differentiation. These researchers showed that these indirect effects were stronger at higher levels of LMX differentiation compared to lower levels. It seems possible that these effects could extend to additional subordinate outcomes and have work-family implications. Scholars are encouraged to employ multi-level approaches of investigating the effects of LMX differentiation and the resulting impact on i-deals and work-family.

Although LMX theory has received considerably more attention in the work-family literature, the integration of additional leadership theories may contribute to a deeper understanding of the connection between these two research areas. More specifically, I advocate for work-family researchers to apply transformational, ethical, and servant leadership theories to provide context for the current study. Major and Litano (2016) specifically emphasized transformational leadership theory to be germane to the work-family interface as these leaders tend to consider and demonstrate genuine concern for their subordinates' unique needs, empower subordinates to think for themselves, and inspire subordinates to behave in a way that aligns with their vision (Bass, 1998; Judge, Woolf, Hurst, & Livingston, 2006). Indeed, initial research has linked transformational leadership to lower WIF and higher WFE (Hammond, Cleveland, O'Neill, Stawski, & Jones-Tate, 2015; Munir, Nielsen, Garde, Albertsen, & Carneiro, 2012). However, transformational leadership theory seems particularly relevant to the negotiation of i-deals as they relate to work-family. For example, transformational leaders may be more open-minded to innovative work roles and/or schedules that facilitate effective work-family management, or may inspire subordinates to pursue work roles that enable them to develop work-family-relevant skills and perspectives. Transformational leaders may be more likely to accept subordinate-initiated i-deals related to work-family, and given that they are more attentive to subordinates' needs, may be more likely to offer such i-deals.

Ethical leadership theory also seems particularly relevant to the negotiation of i-deals in the context of a workgroup. An ethical leader is one who embodies the characteristics of honesty, morality, and are individuals who are fair and principled decision-makers (Brown & Trevino, 2006). Ethical leaders tend to communicate a strong message, agenda, and/or vision, and tend to use rewards and discipline in order to hold subordinates accountable (Brown, Trevino, &

Harrison, 2005; Trevino, Hartman, & Brown, 2000). It seems possible that when ethical leaders authorize i-deals for individuals within a workgroup, the third-party subordinates who do not receive i-deals may be more likely to perceive such an arrangement as earned and justified. Conversely, when i-deals are authorized in workgroups led by unethical supervisors, these third-party subordinates may perceive such arrangements as unwarranted and unfair. Furthermore, this possible interaction between ethical leadership and i-deals on perceptions of fairness may vary based on the type of i-deal being negotiated for (e.g., developmental, flexibility) and the values (e.g., career-oriented, work-family balance) communicated by the leader.

Finally, servant leadership may help to explain both why certain supervisors may be more likely to authorize i-deals as well as why some supervisors are more supportive of employees' efforts to manage work-family. Rather than serving one's one self-interests, the focus of a servant leader is to meet the needs of his or her subordinates (Russell & Stone, 2002). Servant leaders satisfy subordinates' needs to grow and develop, both personally and professionally (Greenleaf, 1977; Stone, Russell, & Patterson, 2004). To the extent that servant leaders understand their subordinates' work-family goals, they may focus on reorganizing one's work role through i-deals to better accommodate their work and family needs.

Practical Implications

This study's findings have critical implications for supervisory and organizational best practices with regard to facilitating employees' work-family management efforts. First, results suggest that supervisors should provide the opportunity to develop high-quality LMX to all their subordinates (Graen & Uhl-Bien, 1991; 1995). Early research on the efficacy of supervisory LMX training suggested that such an intervention results in increased subordinate ratings of supervisor-subordinate relationship quality (Scandura & Graen, 1984). Furthermore, the

subordinates of those supervisors who received the LMX training also realized significant increases in productivity, perceived their supervisors to be more supportive, and were more satisfied with their job and supervisor than the control group (Scandura & Graen, 1984). Such findings suggest that supervisory LMX training may be mutually beneficial. However, since both supervisors and subordinates are key contributors to the development and maintenance of the LMX relationship (Major & Lauzun, 2010), I contend that employees should be included in LMX interventions efforts. Specifically, both supervisors and subordinates may benefit from understanding how to use the LMX model, how to exchange mutual expectations and resources, and developing active listening and relationship skills. Such an approach may help to build both supervisor and subordinate awareness of each other's needs and goals related to work and family.

Second, striving to develop high-quality LMX with each subordinate may have synergistic effects on one's workgroup. Research suggests that one of the ways that LMX is related to work-family is via coworker support (Major et al., 2008). In a large, multi-organizational study, Major and colleagues showed that subordinates who perceived higher-quality LMX also received more support from their coworkers, and this combination of support from multiple sources ameliorated WIF. In fact, with LMX in the model, the organizational work-family culture was not significantly related to coworker support or WIF. As a result, when subordinates experience high-quality relationships with their leaders, they may be more likely to develop supportive relationships among themselves, further enhancing their work-family experience.

Third, results suggest that task i-deals and schedule flexibility i-deals may act as practical levers that supervisors can authorize to improve subordinates' work-family work experience.

Particularly in highly-structured and regulated organizations (e.g., federal government), such personalized work arrangements may make an important difference with respect to subordinates' quality of working life. However, organizations play a critical role in this endeavor. Structured interviews with immediate supervisors revealed that the primary reasons for not granting work-family related requests included lacking of authority, insufficient resources, or that the request was not aligned with company policy (Lauzun et al., 2010). While the current research shows the importance of one's immediate supervisor in negotiating custom work arrangements and the resulting work-family outcomes, Lauzun et al.'s (2010) research suggests that even in the context of high-quality LMX, supervisors may be constrained by organizational structure, policies, and resources. Therefore, organizations should be mindful of practical ways of assisting the supervisor's efforts to facilitate employees' work-family management. One way to do this is to provide formal avenues for employee career development and role flexibility so that supervisors feel empowered to authorize such requests. For example, job rotations may stimulate the development of new skills and responsibilities that increase subordinates' perceptions of work meaningfulness (Hsieh & Chao, 2004; Parker & Wall, 1998). Skills, perspectives, and resources gained in this new work role may then enhance family role functioning. Similarly, rather than offering universal FWA policies, organizations may choose to implement a 'core hours' system which affords employees control over when and where they work, so long as they are available during certain hours (e.g., 10:00am – 2:00pm; Scandura & Lankau, 1997). In addition, organizations should incorporate work-family management into supervisors' performance evaluations. Major and Litano (2016) suggested that holding the supervisor's responsible for his or her own work-family management may positively affect employees' experiences via a more supportive work-family culture. Furthermore, by making supervisors accountable for their

employees' work-family management, they may be more likely to provide relevant work-family resources, including the authorization of i-deals.

Finally, the results of this study suggest that individual employees are powerful agents in managing their own work-family experiences. The foundational premise of LMX theory is that supervisors and subordinates participate in this relationship for mutual benefit (Scandura & Graen, 1984). Thus, subordinates should actively discuss work-family related goals and/or concerns with their supervisors and develop an understanding of the available organizational resources that facilitate effective work-family management. In situations where formal work-family resources are not available, subordinates may be able actively leverage their position in this relationship to negotiate for a more family-accommodating work role.

CHAPTER V

CONCLUSIONS

The current study makes several important contributions to the extant literature by addressing two major limitations in the research examining the relationships between leader-member exchange theory and work-family experiences. First, results suggest that task and schedule flexibility i-deals may act as mediators of the relationships between LMX and work-family enrichment and conflict, respectively. Second, results suggest that LMX had differential effects on work-family experiences depending on which dyad member provided the assessment. Holding the effects of all other variables constant, SLMX was positively related to WFE, and LMX was negatively related to WIF above and beyond the effects of i-deals. Overall, the current research study provides insight into how supervisors can facilitate their employees' efforts to manage work and family, and also identifies i-deals as a potential mechanism that either dyad member can initiate for the benefit of work-family.

REFERENCES

- Agarwal, U. A., Datta, S., Blake-Beard, S., & Bhargava, S. (2012). Linking LMX, innovative work behaviour and turnover intentions: The mediating role of work engagement. *Career Development International, 17*, 208-230. doi: 10.1108/13620431211241063
- Allen, T. D., Johnson, R. C., Kiburz, K. M., & Shockley, K. M. (2013). Work–family conflict and flexible work arrangements: Deconstructing flexibility. *Personnel Psychology, 66*, 345-376. doi: 10.1111/peps.12012
- Allison, P. D. (2002). Missing data: Quantitative applications in the social sciences. *British Journal of Mathematical and Statistical Psychology, 55*, 193-196.
doi: 10.1348/000711002159653
- Amstad, F. T., Meier, L. L., Fasel, U., Elfering, A., & Semmer, N. K. (2011). A meta-analysis of work–family conflict and various outcomes with a special emphasis on cross-domain versus matching-domain relations. *Journal of Occupational Health Psychology, 16*, 151-169. doi: 10.1037/a0022170
- Anand, S., Vidyarthi, P. R., Liden, R. C., & Rousseau, D. M. (2010). Good citizens in poor-quality relationships: Idiosyncratic deals as a substitute for relationship quality. *Academy of Management Journal, 53*, 970-988. doi: 10.5465/AMJ.2010.54533176
- Ashforth, B. E., Kreiner, G. E., & Fugate, M. (2000). All in a day's work: Boundaries and micro role transitions. *Academy of Management Review, 25*, 472-491.
doi: 10.5465/AMR.2000.3363315
- Bandura, A. (1997). *Self-efficacy: The exercise of control*. New York, NY: Freeman.

- Baral, R., & Bhargava, S. (2011). Examining the moderating influence of gender on the relationships between work-family antecedents and work-family enrichment. *Gender in Management: An International Journal*, 26, 122-147. doi: 10.1108/175424111111116545
- Barnett, R. C., & Baruch, G. K. (1985). Women's involvement in multiple roles and psychological distress. *Journal of Personality and Social Psychology*, 49, 135-145. doi: 10.1037/0022-3514.49.1.135
- Becker, Antic, Carlson, Edwards, & Spector (2016). Statistical control in correlational studies: 10 essential recommendations for organizational researchers. *Journal of Organizational Behavior*, 37, 157-167. doi: 10.1002/job.2053
- Bell, B. A., Ene, M., Smiley, W., & Schoeneberger, J. A. (2013). A multilevel model primer using SAS PROC MIXED. Paper presented at the 2013 SAS Global Forum in San Francisco, CA.
- Bentler, P. M. (1990). Comparative fit indexes in structural models. *Psychological Bulletin*, 107, 238-246. doi: 10.1037/0033-2909.107.2.238
- Bernas, K. H., & Major, D. A. (2000). Contributors to stress resistance: Testing a model of women's work-family conflict. *Psychology of Women Quarterly*, 24, 170-178. doi: 10.1111/j.1471-6402.2000.tb00198.x
- Bernerth, J. B., Armenakis, A. A., Feild, H. S., Giles, W. F., & Walker, H. J. (2007). Leader-member social exchange (LMSX): Development and validation of a scale. *Journal of Organizational Behavior*, 28, 979-1003. doi: 10.1002/job.443
- Blau, P. M. (1964). *Exchange and power in social life*. New York, NY: Wiley.

- Bliese, P. D., & Hanges, P. J. (2004). Being both too liberal and too conservative: The perils of treating grouped data as though they were independent. *Organizational Research Methods, 7*, 400-417. doi: 10.1177/1094428104268542
- Bolino, M. C., & Turnley, W. H. (2005). The personal costs of citizenship behavior: The relationship between individual initiative and role overload, job stress, and work-family conflict. *Journal of Applied Psychology, 90*, 740-748. doi: 10.1037/0021-9010.90.4.740
- Briscoe, J. P., Hall, D. T., & Frautschy DeMuth, R. L. (2006). Protean and boundaryless careers: An empirical exploration. *Journal of Vocational Behavior, 69*, 30-47. doi: 10.1016/j.jvb.2005.09.003
- Broschak, J. P., & Davis-Blake, A. (2006). Mixing standard work and nonstandard deals: The consequences of heterogeneity in employment arrangements. *Academy of Management Journal, 49*, 371-393. doi: 10.5465/AMJ.2006.20786085
- Brown, M. E., & Treviño, L. K. (2006). Ethical leadership: A review and future directions. *The Leadership Quarterly, 17*, 595-616. doi: 10.1016/j.leaqua.2006.10.004
- Brown, M. E., Treviño, L. K., & Harrison, D. A. (2005). Ethical leadership: A social learning perspective for construct development and testing. *Organizational Behavior and Human Decision Processes, 97*, 117-134. doi: 10.1016/j.obhdp.2005.03.002
- Byrne, B. M. (2012). *Structural equation modeling with Mplus: Basic concepts, applications, and programming*. New York, NY: Taylor & Francis.
- Carlson, D. S., Grzywacz, J. G., & Kacmar, K. M. (2010). The relationship of schedule flexibility and outcomes via the work-family interface. *Journal of Managerial Psychology, 25*, 330-355. doi: 10.1108/02683941011035278

Carlson, D. S., Grzywacz, J. G., & Zivnuska, S. (2009). Is work-family balance more than conflict and enrichment? *Human Relations*, *62*, 1459-1486.

doi: 10.1177/0018726709336500

Carlson, D. S., Kacmar, K. M., Wayne, J. H., & Grzywacz, J. G. (2006). Measuring the positive side of the work-family interface: Development and validation of a work-family enrichment scale. *Journal of Vocational Behavior*, *68*, 131-164.

doi: 10.1016/j.jvb.2005.02.002

Carlson, D. S., Kacmar, K. M., & Williams, L. J. (2000). Construction and initial validation of a multidimensional measure of work-family conflict. *Journal of Vocational Behavior*, *56*, 249-276. doi: 10.1006/jvbe.1999.1713

Casey, P. R., & Grzywacz, J. G. (2008). Employee health and well-being: The role of flexibility and work-family balance. *The Psychologist-Manager Journal*, *11*, 31-47.

doi: 10.1080/10887150801963885

Cheung, G. W., & Lau, R. S. (2015). Accuracy of parameter estimates and confidence intervals in moderated mediation models: A comparison of regression and latent moderated structural equations. *Organizational Research Methods*, *1-24*.

doi: 10.1177/1094428115595869

Christensen, K. E., & Staines, G. L. (1990). Flextime: A viable solution to work-family conflict? *Journal of Family Issues*, *11*, 455-476. doi: 10.1177/019251390011004007

Clayton, R. W., Thomas, C. H., Singh, B., & Winkel, D. E. (2015). Exercise as a means of reducing perceptions of work-family conflict: A test of the roles of self-efficacy and psychological strain. *Human Resource Management*, *54*, 1013-1035.

doi: 10.1002/hrm.21611

- Cogliser, C. C., Schriesheim, C. A., Scandura, T. A., & Gardner, W. L. (2009). Balance in leader and follower perceptions of leader–member exchange: Relationships with performance and work attitudes. *The Leadership Quarterly*, *20*, 452-465.
doi: 10.1016/j.leaqua.2009.03.010
- Cohen, J., Cohen, P., West, S. G., & Aiken, L. (2003). *Applied multiple regression/correlation analysis for the behavioral sciences* (3rd ed.). New York, NY: Routledge Taylor & Francis Group.
- Crawford, E. R., LePine, J. A., & Rich, B. L. (2010). Linking job demands and resources to employee engagement and burnout: a theoretical extension and meta-analytic test. *Journal of Applied Psychology*, *95*, 834-848. doi: 10.1037/a0019364
- Cropanzano, R., & Mitchell, M. S. (2005). Social exchange theory: An interdisciplinary review. *Journal of Management*, *31*, 874-900. doi: 10.1177/0149206305279602
- Crouter, A. C. (1984). Spillover from family to work: The neglected side of the work-family interface. *Human Relations*, *37*, 425-441. doi: 10.1177/001872678403700601
- Culbertson, S. S., Huffman, A. H., & Alden-Anderson, R. (2009). Leader–member exchange and work–family interactions: the mediating role of self-reported challenge-and hindrance-related stress. *The Journal of Psychology*, *144*, 15-36. doi: 10.1080/00223980903356040
- Dansereau, F., Alutto, J. A., & Yammarino, F. J. (1984). *Theory testing in organisation behaviour: The variant approach*. Englewood Cliffs, NJ: Prentice-Hall.
- Dansereau, F., Graen, G. B., & Haga, W. J. (1975). A vertical dyad linkage approach to leadership within formal organizations: A longitudinal investigation of the role making process. *Organizational Behavior and Human Performance*, *13*, 46-78.
doi: 10.1016/0030-5073(75)90005-7

- Demerouti, E., Bakker, A. B., Nachreiner, F., & Schaufeli, W. B. (2001). The job demands-resources model of burnout. *Journal of Applied Psychology, 86*, 499-512.
doi: 10.1037/0021-9010.86.3.499
- Dienesch, R. M., & Liden, R. C. (1986). Leader-member exchange model of leadership: A critique and further development. *Academy of Management Review, 11*, 618-634.
doi: 10.5465/AMR.1986.4306242
- Direnzo, M. S., Greenhaus, J. H., & Weer, C. H. (2015). Relationship between protean career orientation and work-life balance: A resource perspective. *Journal of Organizational Behavior, 36*, 538-560. doi: 10.1002/job.1996
- Duchon, D., Green, S. G., & Taber, T. D. (1986). Vertical dyad linkage: A longitudinal assessment of antecedents, measures, and consequences. *Journal of Applied Psychology, 71*, 56-60. doi: 10.1037/0021-9010.71.1.56
- Dulebohn, J. H., Bommer, W. H., Liden, R. C., Brouer, R. L., & Ferris, G. R. (2012). A meta-analysis of antecedents and consequences of leader-member exchange: Integrating the past with an eye toward the future. *Journal of Management, 38*, 1715-1759.
doi: 10.1177/0149206311415280
- Dyer, N. G., Hanges, P. J., & Hall, R. J. (2005). Applying multilevel confirmatory factor analysis techniques to the study of leadership. *The Leadership Quarterly, 16*, 149-167.
doi: 10.1016/j.leaqua.2004.09.009
- Edwards, J. R. (2007). Polynomial regression and response surface methodology. In J. R. Edwards, J. A. Shipp, C. Ostroff, & T. A. Judge, (Eds.), *Perspectives on organizational fit* (pp. 361-372).

- Edwards, J. R., & Cable, D. M. (2009). The value of value congruence. *Journal of Applied Psychology, 94*, 654-677. doi: 10.1037/a0014891
- Edwards, J. R., & Lambert, L. S. (2007). Methods for integrating moderation and mediation: A general analytical framework using moderated path analysis. *Psychological Methods, 12*, 1-22. doi: 10.1037/1082-989X.12.1.1
- Edwards, J. R., & Rothbard, N. P. (1999). Work and family stress and well-being: An examination of person-environment fit in the work and family domains. *Organizational Behavior and Human Decision Processes, 77*, 85-129. doi:10.1006/obhd.1998.2813
- Epstein, S. A. (2010). *Applying trait and situational leadership approaches to assess theoretical antecedents of managers' work-life supportive behaviors*. (Doctor of Philosophy doctoral dissertation), University at Albany, State University of New York, Albany, NY.
- Epstein, S. A., Marler, J. H., & Taber, T. D. (2015). Managers' family-supportive supervisory behaviors: A multilevel perspective. *Organization Management Journal, 12*, 49-62. doi: 10.1080/15416518.2015.1037043
- Ford, M. T., Heinen, B. A., & Langkamer, K. L. (2007). Work and family satisfaction and conflict: A meta-analysis of cross-domain relations. *Journal of Applied Psychology, 92*, 57-80. doi: 10.1037/0021-9010.92.1.57
- Friedman, S. D., & Greenhaus, J. H. (2000). *Work and family-allies or enemies? What happens when business professionals confront life choices*. New York, NY: Oxford University Press.
- Frone, M. R. (2003). Work-family balance. In J. C. Quick & L. E. Tetrick (Eds.), *Handbook of occupational health psychology* (pp. 143-162). Washington, DC: American Psychological Association.

- Frone, M. R., Yardley, J. K., & Markel, K. S. (1997). Developing and testing an integrative model of the work–family interface. *Journal of Vocational Behavior, 50*, 145-167.
doi:10.1006/jvbe.1996.1577
- Gerstner, C. R., & Day, D. V. (1997). Meta-analytic review of leader–member exchange theory: Correlates and construct issues. *Journal of Applied Psychology, 82*, 827-844.
doi: 10.1037/0021-9010.82.6.827
- Gouldner, A. W. (1960). The norm of reciprocity: A preliminary statement. *American Sociological Review, 25*, 161-178.
- Graen, G. B., & Cashman, J. F. (1975). A role making model of leadership in formal organizations: A developmental approach. *Leadership Frontiers, 143-165*.
- Graen, G., Novak, M. A., & Sommerkamp, P. (1982). The effects of leader-member exchange and job design on productivity and satisfaction: Testing a dual attachment model. *Organizational Behavior and Human Performance, 30*, 109-131.
doi: 10.1016/0030-5073(82)90236-7
- Graen, G. B., & Scandura, T. A. (1987). Toward a psychology of dyadic organizing. In B. Staw & L. L. Cummings (Eds.), *Research in organizational behavior* (Vol. 9, pp. 175-208). Greenwich, CT: JAI Press.
- Graen, G. B., & Uhl-Bien, M. (1991). The transformation of professionals into self-managing and partially self-designing contributors: Toward a theory of leadership-making. *Journal of Management Systems, 3*, 25-39.
- Graen, G. B., & Uhl-Bien, M. (1995). Relationship-based approach to leadership: Development of leader-member exchange (LMX) theory of leadership over 25 years: Applying a multi-level multi-domain perspective. *The Leadership Quarterly, 6*, 219-247.

doi:10.1016/1048-9843(95)90036-5

Graen, G. B., Wakabayashi, M., Graen, M. R., & Graen, M. G. (1990). International generalizability of American hypotheses about Japanese management progress: A strong inference investigation. *The Leadership Quarterly*, 1, 1-24.

doi:10.1016/1048-9843(90)90012-7

Grandey, A. A., & Cropanzano, R. (1999). The conservation of resources model applied to work-family conflict and strain. *Journal of Vocational Behavior*, 54, 350-370.

doi: 10.1006/jvbe.1998.1666

Greenhaus, J. H., & Allen, T. D. (2011). Work-family balance: A review and extension of the literature. In J. C. Quick & L. E. Tetrick (Eds.), *Handbook of occupational health psychology* (2nd ed., pp. 165-183). Washington, D.C.: American Psychological Association.

Greenhaus, J. H., & Beutell, N. J. (1985). Sources of conflict between work and family roles. *Academy of Management Review*, 76-88. doi: 10.5465/AMR.1985.4277352

Greenhaus, J. H., & Kossek, E. E. (2014). The contemporary career: A work-home perspective. *Annual Review of Organizational Psychology and Organizational Behavior*, 361-388.

doi: 10.1146/annurev-orgpsych-031413-091324

Greenhaus, J. H., & Parasuraman, S. (1999). Research on work, family, and gender: Current status and future directions. In G. N. Powell (Ed.), *Handbook of gender and work* (pp. 391-412). Thousand Oaks, CA: Sage.

Greenhaus, J. H., & Powell, G. N. (2006). When work and family are allies: A theory of work-family enrichment. *Academy of Management Review*, 31, 72-92.

doi: 10.5465/AMR.2006.19379625

- Greenleaf, R. K. (1977). *Servant leadership: A journey into the nature of legitimate power and greatness*. New York, NY: Paulist Press.
- Grilli, L., & Rampichini, C. (2007). Multilevel factor models for ordinal variables. *Structural Equation Modeling: A Multidisciplinary Journal*, *14*, 1-25.
doi: 10.1080/10705510709336734
- Grzywacz, J. G., & Marks, N. F. (2000). Reconceptualizing the work–family interface: An ecological perspective on the correlates of positive and negative spillover between work and family. *Journal of Occupational Health Psychology*, *5*, 111-126.
doi: 10.1037/1076-8998.5.1.111
- Hackman, J. R., & Oldham, G. R. (1976). Motivation through the design of work: Test of a theory. *Organizational Behavior and Human Performance*, *16*, 250-279.
doi: 10.1016/0030-5073(76)90016-7
- Hackman, J. R., & Oldham, G. R. (1980). *Work redesign*. Reading, MA: Addison-Wesley.
- Hall, D. T. (1976). *Careers in organizations*. Santa Monica, CA: Goodyear Publishing Company.
- Hammer, L. B., Kossek, E. E., Yragui, N. L., Bodner, T. E., & Hanson, G. C. (2009). Development and validation of a multidimensional measure of family supportive supervisor behaviors (FSSB). *Journal of Management*, *35*, 837-856.
doi: 10.1177/0149206308328510
- Henderson, D. J., Liden, R. C., Glibkowski, B. C., & Chaudhry, A. (2009). LMX differentiation: A multilevel review and examination of its antecedents and outcomes. *The Leadership Quarterly*, *20*, 517-534. doi: 10.1016/j.leaqua.2009.04.003

- Hill, E. J., Hawkins, A. J., & Miller, B. C. (1996). Work and family in the virtual office: Perceived influences of mobile telework. *Family Relations*, 293-301.
doi: 10.2307/585501
- Hill, E. J., Jacob, J. I., Shannon, L. L., Brennan, R. T., Blanchard, V. L., & Martinengo, G. (2008). Exploring the relationship of workplace flexibility, gender, and life stage to family-to-work conflict, and stress and burnout. *Community, Work and Family*, 11, 165-181. doi: 10.1080/13668800802027564
- Hill, R. T., Morganson, V. J., Matthews, R. A., & Atkinson, T. P. (2016). LMX, breach perceptions, work-family conflict, and well-being: A mediational model. *The Journal of Psychology*, 150, 132-149. doi: 10.1080/00223980.2015.1014307
- Hobfoll, S. E. (1989). Conservation of resources: A new attempt at conceptualizing stress. *American Psychologist*, 44, 513-524. doi: 10.1037/0003-066X.44.3.513
- Hobfoll, S. E. (2001). The influence of culture, community, and the nested-self in the stress process: Advancing conservation of resources theory. *Applied Psychology*, 50, 337-421. doi: 10.1111/1464-0597.00062
- Hofstede, G., Hofstede, G. J., & Minkov, M. (2010). *Cultures and organizations: Software of the mind* (3rd ed.). New York, NY: McGraw-Hill.
- Hohl, K. L. (1996). The effects of flexible work arrangements. *Nonprofit Management and Leadership*, 7, 69-86. doi: 10.1002/nml.4130070107
- Hooper, D. T., & Martin, R. (2008). Beyond personal leader-member exchange (LMX) quality: The effects of perceived LMX variability on employee reactions. *The Leadership Quarterly*, 19, 20-30. doi: 10.1016/j.leaqua.2007.12.002

- Hornung, S., Glaser, J., Rousseau, D. M., Angerer, P., & Weigl, M. (2011). Employee-oriented leadership and quality of working life: Mediating roles of idiosyncratic deals. *Psychological Reports, 108*, 59-74. doi: 10.2466/07.13.14.21.pr0.108.1.59-74
- Hornung, S., Rousseau, D. M., & Glaser, J. (2008). Creating flexible work arrangements through idiosyncratic deals. *Journal of Applied Psychology, 93*, 655-664. doi: 10.1037/0021-9010.93.3.655
- Hornung, S., Rousseau, D. M., & Glaser, J. (2009). Why supervisors make idiosyncratic deals: Antecedents and outcomes of i-deals from a managerial perspective. *Journal of Managerial Psychology, 24*, 738-764. doi: 10.1108/02683940910996770
- Hornung, S., Rousseau, D. M., Glaser, J., Angerer, P., & Weigl, M. (2010). Beyond top-down and bottom-up work redesign: Customizing job content through idiosyncratic deals. *Journal of Organizational Behavior, 31*, 187-215. doi: 10.1002/job.625
- Hornung, S., Rousseau, D. M., Weigl, M., Müller, A., & Glaser, J. (2014). Redesigning work through idiosyncratic deals. *European Journal of Work and Organizational Psychology, 23*, 608-626. doi: 10.1080/1359432X.2012.740171
- Hsieh, A. T., & Chao, H. Y. (2004). A reassessment of the relationship between job specialization, job rotation and job burnout: example of Taiwan's high-technology industry. *The International Journal of Human Resource Management, 15*, 1108-1123. doi: 10.1080/09585190410001677331
- Hu, L., & Bentler, P. M. (1999). Cutoff criteria for fit indexes in covariance structure analysis: Conventional criteria versus new alternatives. *Structural Equation Modeling: A Multidisciplinary Journal, 6*, 1-55. doi: 10.1080/10705519909540118

- Humphrey, S. E., Nahrgang, J. D., & Morgeson, F. P. (2007). Integrating motivational, social, and contextual work design features: A meta-analytic summary and theoretical extension of the work design literature. *Journal of Applied Psychology, 92*, 1332-1356.
doi: 10.1037/0021-9010.92.5.1332
- Jackson, E. M., & Johnson, R. E. (2012). When opposites do (and do not) attract: Interplay of leader and follower self-identities and its consequences for leader–member exchange. *The Leadership Quarterly, 23*, 488-501. doi:10.1016/j.leaqua.2011.12.003
- Kacmar, K. M., Crawford, W. S., Carlson, D. S., Ferguson, M., & Whitten, D. (2014). A short and valid measure of work-family enrichment. *Journal of Occupational Health Psychology, 19*, 32-45. doi: 10.1037/a0035123
- Kacmar, K. M., Witt, L. A., Zivnuska, S., & Gully, S. M. (2003). The interactive effect of leader-member exchange and communication frequency on performance ratings. *Journal of Applied Psychology, 88*, 764-772. doi: 10.1037/0021-9010.88.4.764
- Kahn, R. L., Wolfe, D. M., Quinn, R. P., Snoek, J. D., & Rosenthal, R. A. (1964). *Organizational stress: Studies in role conflict and ambiguity*. New York, NY: Wiley.
- Kelly, E. L., & Kalev, A. (2006). Managing flexible work arrangements in US organizations: Formalized discretion or ‘a right to ask’. *Socio-Economic Review, 4*, 379-416.
doi: 10.1093/ser/mwl001
- Kenny, D. A., Kaniskan, B., & McCoach, D. B. (2015). The performance of RMSEA in models with small degrees of freedom. *Sociological Methods & Research, 44*, 486-507.
doi: 10.1177/0049124114543236
- Kirchmeyer, C. (1992). Nonwork participation and work attitudes: A test of scarcity vs. expansion models of personal resources. *Human Relations, 45*, 775-795.

doi: 10.1177/001872679204500802

Kirchmeyer, C. (2000). Work-life initiatives: Greed or benevolence regarding workers' time? In C. L. Cooper & D. M. Rousseau (Eds.), *Trends in organizational behavior: Time in organizational behavior* (Vol. 7, pp. 79-94). Chichester, England: Wiley.

Kline, R. B. (2011). *Principles and practice of structural equation modeling* (3rd ed.). New York, NY: Guilford Press.

Kossek, E. E., Pichler, S., Bodner, T., & Hammer, L. B. (2011). Workplace social support and work-family conflict: A meta-analysis clarifying the influence of general and work-family-specific supervisor and organizational support. *Personnel Psychology*, 64, 289-313. doi: 10.1111/j.1744-6570.2011.01211.x

Krasikova, D. V., & LeBreton, J. M. (2012). Just the two of us: Misalignment of theory and methods in examining dyadic phenomena. *Journal of Applied Psychology*, 97, 739-757. doi: 10.1037/a0027962

Kristof-Brown, A. L., Zimmerman, R. D., & Johnson, R. C. (2005). Consequences of individuals' fit at work: A meta-analysis of person-job, person-organization, person-group, and person-supervisor fit. *Personnel Psychology*, 58, 281-342. doi: 10.1111/j.1744-6570.2005.00672.x

Lambert, A. D., Marler, J. H., & Gueutal, H. G. (2008). Individual differences: Factors affecting employee utilization of flexible work arrangements. *Journal of Vocational Behavior*, 73, 107-117. doi: 10.1016/j.jvb.2008.02.004

Lapierre, L. M., & Allen, T. D. (2006). Work-supportive family, family-supportive supervision, use of organizational benefits, and problem-focused coping: implications for work-family

- conflict and employee well-being. *Journal of Occupational Health Psychology*, *11*, 169-181. doi: 10.1037/1076-8998.11.2.169
- Lauzun, H. M., Morganson, V. J., Major, D. A., & Green, A. P. (2010). Seeking work-life balance: Employees' requests, supervisors' responses, and organizational barriers. *The Psychologist-Manager Journal*, *13*, 184-205. doi: 10.1080/10887156.2010.500953
- LePine, J. A., LePine, M. A., & Jackson, C. L. (2004). Challenge and hindrance stress: Relationships with exhaustion, motivation to learn, and learning performance. *Journal of Applied Psychology*, *89*, 883-891. doi: 10.1037/0021-9010.89.5.883
- Li, A., Shaffer, J., & Bagger, J. (2015). The psychological well-being of disability caregivers: Examining the roles of family strain, family-to-work conflict, and perceived supervisor support. *Journal of Occupational Health Psychology*, *20*, 40-49. doi: 10.1037/a0037878
- Liao, C., Wayne, S. J., Liden, R. C., & Meuser, J. D. (2016). Idiosyncratic deals and individual effectiveness: The moderating role of leader-member exchange differentiation. *The Leadership Quarterly*. Pagination not yet specified.
- Liao, C., Wayne, S. J., & Rousseau, D. M. (2014). Idiosyncratic deals in contemporary organizations: A qualitative and meta-analytical review. *Journal of Organizational Behavior*, Pagination not yet specified. doi: 10.1002/job.1959
- Liden, R. C., & Maslyn, J. M. (1998). Multidimensionality of leader-member exchange: An empirical assessment through scale development. *Journal of Management*, *24*, 43-72. doi: 10.1177/014920639802400105
- Liden, R. C., Sparrowe, R. T., & Wayne, S. J. (1997). Leader-member exchange theory: The past and potential for the future. In G. R. Ferris (Ed.), *Research in personnel and human resources management* (Vol. 15). US: Elsevier Science/JAI Press.

- Liden, R. C., Wayne, S. J., & Stilwell, D. (1993). A longitudinal study on the early development of leader-member exchanges. *Journal of Applied Psychology, 78*, 662-674.
doi: 10.1037/0021-9010.78.4.662
- Liden, R. C., Wu, J., Cao, A. X., & Wayne, S. J. (2015). Leader–member exchange measurement. In T. N. Bauer & B. Erdogan (Eds.), *The Oxford handbook of leader-member exchange*. New York, NY: Oxford University Press.
- Litano, M. L., & Major, D. A. (2016). Facilitating a whole-life approach to career development: The role of organizational leadership. *Journal of Career Development, 43*, 52-65.
doi: 10.1177/0894845315569303
- Litano, M. L., & Major, D. A. (2015, March). *The differential impact of leader-member exchange and family-supportive supervisor behaviors on work-family outcomes*. Poster presented at the Inaugural International Convention of Psychological Science, Amsterdam, the Netherlands.
- Litano, M. L., Major, D. A., Streets, V. N., Landers, R. N., & Bass, B. I. (2016). A meta-analytic investigation of the relationship between leader-member exchange and work-family experiences. *The Leadership Quarterly, 5*, 802-817. doi: 10.1016/j.leaqua.2016.06.003
- Litano, M. L., McGowan, A. M. R, & Rogers, L. (2016). Links between organizational culture and team performance at NASA Langley Research Center. Technical report presented at NASA Langley Research Center, Hampton, VA. TPSAS Reference number 26079.
- Litano, M. L., Myers, D. P., & Major, D. A. (2014). How can men and women be allies in achieving work-family balance? The role of coping in facilitating positive crossover. In D. A. Major & R. J. Burke (Eds.), *Gender in organizations: Are men allies or adversaries to women's career advancement?* Cheltenham, UK: Edward Elgar.

- Little, R. J. (1988). A test of missing completely at random for multivariate data with missing values. *Journal of the American Statistical Association*, 83, 1198-1202.
doi: 10.1080/01621459.1988.10478722
- Little, T. D., Bovaird, J. A., & Widaman, K. F. (2006). On the merits of orthogonalizing powered and product terms: Implications for modeling interactions among latent variables. *Structural Equation Modeling*, 13, 497-519. doi: 10.1207/s15328007sem1304_1
- Livingston, G. (2013). *Among 38 nations, U.S. is the outlier when it comes to paid parental leave*. Washington, DC: PEW Research Center.
- Major, D. A., Burke, R. J., & Fiskensbaum, L. M. (2013). Work and family life: Revitalizing research and practice. In D. A. Major & R. J. Burke (Eds.), *Handbook of work-life integration among professionals: Challenges and opportunities*. Cheltenham, UK: Edward Elgar.
- Major, D. A., & Cleveland, J. N. (2007). Strategies for reducing work-family conflict: Applying research and best practices from industrial and organizational psychology. In G. P. Hodgkinson & J. K. Ford (Eds.), *International review of industrial and organizational psychology* (Vol. 22). West Sussex, England: John Wiley & Sons, Ltd.
- Major, D. A., Fletcher, T. D., Davis, D. D., & Germano, L. M. (2008). The influence of work-family culture and workplace relationships on work interference with family: A multilevel model. *Journal of Organizational Behavior*, 29, 881-897. doi: 10.1002/job.502
- Major, D. A., & Germano, L. M. (2006). The changing nature of work and its impact on the work-home interface. In F. Jones, R. J. Burke, & M. Westman (Eds.), *Work-life balance: A psychological perspective* (pp. 13-38). New York, NY: Psychology Press.

- Major, D. A., & Lauzun, H. M. (2010). Equipping managers to assist employees in addressing work-family conflict: Applying the research literature toward innovative practice. *The Psychologist-Manager Journal*, *13*, 69-85. doi: 10.1080/10887151003761275
- Major, D. A., Lauzun, H. M., & Jones, M. P. (2013). New directions in work-family coping research. In J. H. Greenhaus & M. Maestri (Eds.), *Expanding the boundaries of work-family research: A vision for the future* (pp. 193-211). New York, NY: Palgrave Macmillan.
- Major, D. A., & Litano, M. L. (2014). The role of adaptability in work-family conflict and coping. In D. Chan (Ed.), *Responding to changes at work: New directions in research on individual adaptability* (pp. 115-133). New York, NY: Taylor & Francis Group.
- Major, D. A., & Litano, M. L. (2016). The importance of organizational leadership in managing work and family. In T. D. Allen & L. T. Eby (Eds.), *The Oxford handbook of work and family* (pp. 242-254). New York, NY: Oxford University Press.
- Major, D. A., & Morganson, V. J. (2011). Coping with work-family conflict: A leader-member exchange perspective. *Journal of Occupational Health Psychology*, *16*, 126-138. doi: 10.1037/a0021727
- Markham, S. E., Yammarino, F. J., Murry, W. D., & Palanski, M. E. (2010). Leader-member exchange, shared values, and performance: Agreement and levels of analysis do matter. *The Leadership Quarterly*, *21*, 469-480. doi:10.1016/j.leaqua.2010.03.010
- Marks, S. R. (1977). Multiple roles and role strain: Some notes on human energy, time and commitment. *American Sociological Review*, 921-936.

- Martinengo, G., Jacob, J. I., & Hill, E. J. (2010). Gender and the work-family interface: Exploring differences across the family life course. *Journal of Family Issues, 31*, 1363-1390. doi: 10.1177/0192513X10361709
- Maslyn, J. M., & Uhl-Bien, M. (2001). Leader-member exchange and its dimensions: Effects of self-effort and other's effort on relationship quality. *Journal of Applied Psychology, 86*, 697-708. doi: 10.1037/0021-9010.86.4.697
- Matos, K., & Galinsky, E. (Producer). (2014). National study of employers. Retrieved from <http://familiesandwork.org/downloads/2014NationalStudyOfEmployers.pdf>
- Matta, F. K., Scott, B. A., Koopman, J., & Conlon, D. E. (2015). Does seeing “eye to eye” affect work engagement and organizational citizenship behavior? A role theory perspective on LMX agreement. *Academy of Management Journal, 58*, 1686-1708. doi: 10.5465/amj.2014.0106
- Matthews, R. A., Bulger, C. A., & Booth, S. M. (2013). Managing the work-family interface to the benefit of both subordinates and supervisors: Looking beyond supervisor support and focusing on leadership behaviors. In M. Paludi (Ed.), *Psychology for business success, Vol. 1: Juggling, balancing, and integrating work and family roles and responsibilities* (pp. 153-170). Santa Barbara, CA: Praeger/ABC-CLIO.
- Matthews, R. A., & Toumbeva, T. H. (2015). Lagged effects of family-supportive organization perceptions and supervision in relation to generalized work-related resources. *Journal of Occupational Health Psychology, 20*, 301-313. doi: 10.1037/a0038377
- McNall, L. A., Masuda, A. D., & Nicklin, J. M. (2009). Flexible work arrangements, job satisfaction, and turnover intentions: The mediating role of work-to-family enrichment. *The Journal of Psychology, 144*, 61-81. doi: 10.1080/00223980903356073

- McNall, L. A., Nicklin, J. M., & Masuda, A. D. (2010). A meta-analytic review of the consequences associated with work–family enrichment. *Journal of Business and Psychology, 25*, 381-396. doi: 10.1037/a0038165
- McNall, L. A., Scott, L. D., & Nicklin, J. M. (2015). Do positive affectivity and boundary preferences matter for work–family enrichment? A study of human service workers. *Journal of Occupational Health Psychology, 20*, 93-104. doi: 10.1037/a0038165
- Meade, A. W., & Craig, S. B. (2012). Identifying careless responses in survey data. *Psychological Methods, 17*, 437-455. doi: 10.1037/a0028085
- Michel, J. S., & Clark, M. A. (2013). Investigating the relative importance of individual differences on the work–family interface and the moderating role of boundary preference for segmentation. *Stress and Health, 29*, 324-336. doi: 10.1002/smi.2474
- Michel, J. S., Kotrba, L. M., Mitchelson, J. K., Clark, M. A., & Baltes, B. B. (2011). Antecedents of work–family conflict: A meta-analytic review. *Journal of Organizational Behavior, 32*, 689-725. doi: 10.1002/job.695
- Mustafa, M. (2010). Managing Boundaries: The case of home-based self-employed teleworkers. *International Journal of Business and Management Research, 3*, 55-64.
- Muthén, L. K., & Muthén, B. O. (2002). How to use a Monte Carlo study to decide on sample size and determine power. *Structural Equation Modeling, 9*, 599-620.
doi: 10.1207/S15328007SEM0904_8
- Muthén, L. K., & Muthén, B. O. (2015). *Mplus user's guide* (7.4 ed.). Los Angeles, CA: Muthén & Muthén.

- Netemeyer, R. G., Boles, J. S., & McMurrian, R. (1996). Development and validation of work–family conflict and family–work conflict scales. *Journal of Applied Psychology, 81*, 400-410. doi: 10.1037/0021-9010.81.4.400
- Organization for Economic Cooperation and Development. (2011). *OECD Family Database*. OECD Publishing, Paris, France.
- Parker, S. K., & Wall, T. D. (1998). *Job and work design: Organizing work to promote well-being and effectiveness* (Vol. 4). Thousand Oaks, CA: Sage.
- Paustian-Underdahl, S. C., Halbesleben, J. R., Carlson, D. S., & Kacmar, K. M. (2013). The work–family interface and promotability boundary integration as a double-edged sword. *Journal of Management, 42*, 960-981. doi: 10.1177/0149206313506464
- Pierce, J. L., Jussila, I., & Cummings, A. (2009). Psychological ownership within the job design context: Revision of the job characteristics model. *Journal of Organizational Behavior, 30*, 477-496. doi: 10.1002/job.550
- Pleck, J. H. (1977). The work-family role system. *Social Problems, 417-427*. doi: 10.2307/800135
- Podsakoff, P. M., MacKenzie, S. B., Lee, J. Y., & Podsakoff, N. P. (2003). Common method biases in behavioral research: A critical review of the literature and recommended remedies. *Journal of Applied Psychology, 88*, 879-903. doi: 10.1037/0021-9010.88.5.879
- Podsakoff, P. M., MacKenzie, S. B., & Podsakoff, N. P. (2012). Sources of method bias in social science research and recommendations on how to control it. *Annual Review of Psychology, 63*, 539-569. doi: 10.1146/annurev-psych-120710-100452

- Preacher, K. J., Rucker, D. D., & Hayes, A. F. (2007). Addressing moderated mediation hypotheses: Theory, methods, and prescriptions. *Multivariate Behavioral Research*, 42, 185-227. doi: 10.1080/00273170701341316
- Raudenbush, S. W., & Bryk, A. S. (2002). *Hierarchical linear models: Applications and data analysis methods* (2nd ed.). Thousand Oaks, CA: Sage.
- Rosen, C. C., Slater, D. J., & Johnson, R. E. (2013). Let's make a deal: Development and validation of the ex post I-deals scale. *Journal of Management*, 39, 709-742. doi: 10.1177/0149206310394865
- Rousseau, D. M. (2001). The idiosyncratic deal: Flexibility versus fairness? *Organizational Dynamics*, 29, 260-273. doi: 10.1016/S0090-2616(01)00032-8
- Rousseau, D. M. (2005). *I-deals: Idiosyncratic deals employees bargain for themselves*. Armonk, NY: M. E. Sharpe.
- Rousseau, D. M., Ho, V. T., & Greenberg, J. (2006). I-deals: Idiosyncratic terms in employment relationships. *Academy of Management Review*, 31, 977-994. doi: 10.5465/AMR.2006.22527470
- Rousseau, D. M., Hornung, S., & Kim, T. G. (2009). Idiosyncratic deals: Testing propositions on timing, content, and the employment relationship. *Journal of Vocational Behavior*, 74, 338-348. doi:10.1016/j.jvb.2009.02.004
- Russell, R. F., & Gregory Stone, A. (2002). A review of servant leadership attributes: Developing a practical model. *Leadership & Organization Development Journal*, 23, 145-157. doi: 10.1108/01437730210424
- Satorra, A. (2000). Scaled and adjusted restricted tests in multi-sample analysis of moment structures. In Heijmans, R.D.H., Pollock, D.S.G. & Satorra, A. (eds.), *Innovations in*

- multivariate statistical analysis. A festschrift for heinz neudecker* (pp. 233-247). London: Kluwer Academic Publishers.
- Scandura, T. A., & Graen, G. B. (1984). Moderating effects of initial leader–member exchange status on the effects of a leadership intervention. *Journal of Applied Psychology, 69*, 428-436. doi: 10.1037/0021-9010.69.3.428
- Scandura, T. A., & Lankau, M. J. (1997). Relationships of gender, family responsibility and flexible work hours to organizational commitment and job satisfaction. *Journal of Organizational Behavior, 18*, 377-391.
- Scandura, T. A., & Schriesheim, C. A. (1994). Leader-member exchange and supervisor career mentoring as complementary constructs in leadership research. *Academy of Management Journal, 37*, 1588-1602. doi: 10.2307/256800
- Schaufeli, W. B., & Bakker, A. B. (2004). Job demands, job resources, and their relationship with burnout and engagement: A multi-sample study. *Journal of Organizational Behavior, 25*, 293-315. doi: 10.1002/job.248
- Schumacker, R. E., & Lomax, R. G. (2004). *A beginner's guide to structural equation modeling* (2nd ed.). Mahwah, NJ: Lawrence Erlbaum Associates.
- Schriesheim, C. A., Wu, J. B., & Cooper, C. D. (2011). A two-study investigation of item wording effects on leader–follower convergence in descriptions of the leader–member exchange (LMX) relationship. *The Leadership Quarterly, 22*, 881-892. doi: 10.1016/j.leaqua.2011.07.009
- Sin, H. P., Nahrgang, J. D., & Morgeson, F. P. (2009). Understanding why they don't see eye to eye: An examination of leader–member exchange (LMX) agreement. *Journal of Applied Psychology, 94*, 1048-1057. doi: 10.1037/a0014827

- Spector, P. E. (2006). Method variance in organizational research: Truth or urban legend? *Organizational Research Methods, 9*, 221-232. doi: 10.1177/1094428105284955
- Spector & Brannick (2011). Methodological urban legends: The misuse of statistical control variables. *Organizational Research Methods, 14*, 287-305.
doi: 10.1177/1094428110369842
- Stolz, M. L. (2012). *Work-life in Germany*. Boston College Center for Work and Family: Executive Briefing Series, Boston, MA.
- Stone, A. G., Russell, R. F., & Patterson, K. (2004). Transformational versus servant leadership: A difference in leader focus. *Leadership & Organization Development Journal, 25*, 349-361. doi: 10.1108/01437730410538671
- Sullivan, C., & Lewis, S. (2001). Home-based telework, gender, and the synchronization of work and family: perspectives of teleworkers and their co-residents. *Gender, Work & Organization, 8*, 123-145. doi: 10.1111/1468-0432.00125
- Swody, C. A., & Powell, G. N. (2007). Determinants of employee participation in organizations' family-friendly programs: A multi-level approach. *Journal of Business and Psychology, 22*, 111-122. doi: 10.1007/s10869-007-9057-6
- Tang, Y., & Hornung, S. (2015). Work-family enrichment through i-deals: Evidence from Chinese employees. *Journal of Managerial Psychology, 30*, 940-954.
doi: 10.1108/JMP-02-2013-0064
- Thomas, L. T., & Ganster, D. C. (1995). Impact of family-supportive work variables on work-family conflict and strain: A control perspective. *Journal of Applied Psychology, 80*, 6-15. doi: 10.1037/0021-9010.80.1.6

- Thompson, C. A., Beauvais, L. L., & Lyness, K. S. (1999). When work–family benefits are not enough: The influence of work–family culture on benefit utilization, organizational attachment, and work–family conflict. *Journal of Vocational Behavior, 54*, 392-415. doi: 10.1006/jvbe.1998.1681
- Thompson, C. A., & Prottas, D. J. (2006). Relationships among organizational family support, job autonomy, perceived control, and employee well-being. *Journal of Occupational Health Psychology, 11*, 100-118. doi: 10.1037/1076-8998.10.4.100
- Tremblay, D. G., Paquet, R., & Najem, E. (2006). Telework: A way to balance work and family or an increase in work-family conflict? *Canadian Journal of Communication, 31*, 715-731.
- Trevino, L. K., Hartman, L. P., & Brown, M. (2000). Moral person and moral manager: How executives develop a reputation for ethical leadership. *California Management Review, 42*, 128-142. doi: 10.2307/41166057
- Tummers, L. G., & Bronkhorst, B. A. C. (2014). The impact of leader-member exchange (LMX) on work-family interference and work-family facilitation. *Personnel Review, 43*, 573-591. doi: 10.1108/PR-05-2013-0080
- U.S. Bureau of Labor Statistics. (2014). *Women in the labor force: A databook*. (Report 1052). Washington, DC; U.S. Government Printing Office.
- U.S. Bureau of Labor Statistics. (2013). *Women in the labor force: A databook*. (Report 1049). Washington, DC; U.S. Government Printing Office.
- Tummers, L. G., & Knies, E. (2013). Leadership and meaningful work in the public sector. *Public Administration Review, 73*, 859-868. doi: 10.1111/puar.12138

- van Gils, S., van Quaquebeke, N., & van Knippenberg, D. (2010). The X-factor: On the relevance of implicit leadership and followership theories for leader–member exchange agreement. *European Journal of Work and Organizational Psychology, 19*, 333-363. doi: 10.1080/13594320902978458
- Vidyarathi, P. R., Erdogan, B., Anand, S., Liden, R. C., & Chaudhry, A. (2014). One member, two leaders: Extending leader–member exchange theory to a dual leadership context. *Journal of Applied Psychology, 99*, 468-483. doi: 10.1037/a0035466
- Wang, H., Law, K. S., Hackett, R. D., Wang, D., & Chen, Z. X. (2005). Leader-member exchange as a mediator of the relationship between transformational leadership and followers' performance and organizational citizenship behavior. *Academy of Management Journal, 48*, 420-432. doi: 10.5465/AMJ.2005.17407908
- Wayne, J. H., Butts, M. M., Casper, W. J., & Allen, T. D. (2015). A conceptual and empirical integration of multiple meanings of work-family balance. *Personnel Psychology*, Pagination not specified. doi: 10.1111/peps.12132
- Wayne, S. J., Shore, L. M., & Liden, R. C. (1997). Perceived organizational support and leader-member exchange: A social exchange perspective. *Academy of Management Journal, 82*-111. doi: 10.2307/257021
- Weinfurt, K. P. (2010). Repeated measures analysis: ANOVA, MANOVA, and HLM. In L. G. Grimm & P. R. Yarnold (Eds.), *Reading and understanding more multivariate statistics*. Washington, D. C.: American Psychological Association.
- Wolf, E. J., Harrington, K. M., Clark, S. L., & Miller, M. W. (2013). Sample size requirements for structural equation models an evaluation of power, bias, and solution propriety. *Educational and Psychological Measurement, 73*, 913-934.

doi: 10.1177/0013164413495237

Woltman, H., Feldstain, A., MacKay, J. C., & Rocchi, M. (2012). An introduction to hierarchical linear modeling. *Tutorials in Quantitative Methods for Psychology*, 8, 52-69.

Wrzesniewski, A., & Dutton, J. E. (2001). Crafting a job: Revisioning employees as active crafters of their work. *Academy of Management Review*, 26, 179-201.

doi: 10.5465/AMR.2001.4378011

Wu, J., & Taber, T. D. (2009). *LMX and leader's delegation of responsibility, trust and effectiveness ratings of subordinates*. Paper presented at the Academy of Management, Chicago, IL.

Yang, L., Levine, E. L., Smith, M. A., Ispas, D., & Rossi, M. E. (2008). Person–environment fit or person plus environment: A meta-analysis of studies using polynomial regression analysis. *Human Resource Management Review*, 18, 311-321.

doi: 10.1016/j.hrmr.2008.07.014

Zhou, X., & Schriesheim, C. A. (2009). Supervisor–subordinate convergence in descriptions of leader–member exchange (LMX) quality: Review and testable propositions. *The Leadership Quarterly*, 20, 920-932. doi:10.1016/j.leaqua.2009.09.007

Zhou, X., & Schriesheim, C. A. (2010). Quantitative and qualitative examination of propositions concerning supervisor–subordinate convergence in descriptions of leader–member exchange (LMX) quality. *The Leadership Quarterly*, 21, 826-843.

doi: <http://dx.doi.org/10.1016/j.leaqua.2010.07.010>

APPENDIX A**WORK INTERFERENCE WITH FAMILY SCALE**

Items

1. The demands of my work interfere with my home and family life.
2. The amount of time my job takes up makes it difficult to fulfill family responsibilities.
3. Things I want to do at home do not get done because of the demands my job puts on me.
4. My job produces strain that makes it difficult to fulfill family duties.
5. Due to work-related duties, I have to make changes to my plans for family activities.

Note. From Netemeyer, Boles, and McMurrian (1996). Responses range from 1 (*strongly disagree*) to 5 (*strongly agree*).

APPENDIX B**WORK-TO-FAMILY ENRICHMENT SCALE**

Items

“My involvement in my work...”

1. Helps me to understand different viewpoints and this helps me be a better family member.
2. Makes me feel happy and this helps me be a better family member.
3. Helps me feel personally fulfilled and this helps me be a better family member.

Note. From Kacmar, Crawford, Carlson, Ferguson, and Whitten (2014). Responses range from 1 (*strongly disagree*) to 5 (*strongly agree*).

APPENDIX C

IDIOSYNCRATIC DEALS SCALE

Items

“Please report to what extent you have asked for and **successfully negotiated** for the following **personalized conditions** in your current job:”

Schedule flexibility

1. Flexibility in starting and ending my work day.^a
2. A work schedule customized to my personal needs.^a
3. Work hours that are accommodating of my off-the-job demands.^b
4. Time off (outside of formal leave and sick time) to attend to non-work related issues.^b

Location flexibility

5. The ability to complete a portion of my work outside of the office.^b
6. Approval to work from a location that is accommodating of my personal circumstances.^b
7. Flexibility to work from home or another convenient location.^c

Task

8. Flexibility in how I complete my job tasks.^b
9. Extra tasks or responsibilities that better fit my personality, skills, and abilities.^b
10. Personally motivating job tasks.^a
11. Job tasks that fit my personal strengths, talents, and interests.^a

Career

12. Opportunities to take on desired responsibilities outside of my formal job requirements.^b
13. Personal career development opportunities.^a
14. Opportunities for training or education related to my professional development.^c
15. Career options that suit my personal goals.^a

Note. Item prompt is borrowed from Rousseau & Kim (2006) and Hornung et al. (2014). ^a indicates that the item comes from Hornung et al. (2014) measure, which was adapted from Hornung et al. (2008). ^b indicates that the item was adapted from Rosen, Slater, & Johnson (2013) to better fit the item prompt and to eliminate double-barreled items. ^c indicates that the item was developed for this study by the researcher. Responses range from 1 (*not at all*) to 5 (*to a great extent*).

APPENDIX D

SUBORDINATE-RATED LEADER-MEMBER EXCHANGE SCALE

Items

1. Do you know where you stand with your leader; do you usually know how satisfied your leader is with what you do? (Responses: Rarely, Occasionally, Sometimes, Fairly Often, Very Often)
 2. How well does your leader understand your job problems and needs? (Responses: Not a Bit, A Little, A Fair Amount, Quite a Bit, A Great Deal)
 3. How well does your leader recognize your potential? (Responses: Not at All, A Little, Moderately, Mostly, Fully)
 4. Regardless of how much formal authority he/she has built into his/her position, what are the chances that your leader would use his/her power to help you solve problems in your work? (Responses: None, Small, Moderate, High, Very High)
 5. Again, regardless of the amount of formal authority your leader has, what are the chances that he/she would “bail you out” at his/her expense? (Responses: None, Small, Moderate, High, Very High)
 6. I have enough confidence in my leader that I would defend and justify his/her decisions if he/she were not present to do so. (Responses: Strongly Disagree, Disagree, Neutral, Agree, Strongly Agree)
 7. How would you characterize your working relationship with your leader? (Responses: Extremely Ineffective, Worse Than Average, Average, Better Than Average, Extremely Effective)
-

Note. From Graen, Novak, & Sommerkamp (1982). Response scales vary and are listed above with the corresponding item.

APPENDIX E

SUPERVISOR-RATED LEADER-MEMBER EXCHANGE SCALE

Items

1. Do you know where you stand with this employee; do you usually know how satisfied this employee is with what you do? (Responses: Rarely, Occasionally, Sometimes, Fairly Often, Very Often)
2. How well does this employee understand your job problems and needs? (Responses: Not a Bit, A Little, A Fair Amount, Quite a Bit, A Great Deal)
3. How well does this employee recognize your potential? (Responses: Not at All, A Little, Moderately, Mostly, Fully)
4. Regardless of how much formal authority he/she has built into his/her position, what are the chances that this employee would use his/her power to help you solve problems in your work? (Responses: None, Small, Moderate, High, Very High)
5. Again, regardless of the amount of formal authority this employee has, what are the chances that he/she would "bail you out" at his/her expense? (Responses: None, Small, Moderate, High, Very High)
6. I have enough confidence in this employee that I would defend and justify his/her decisions if he/she were not present to do so. (Responses: Strongly Disagree, Disagree, Neutral, Agree, Strongly Agree)
7. How would you characterize your working relationship with this employee? (Responses: Extremely Ineffective, Worse Than Average, Average, Better Than Average, Extremely Effective)

Note. From Maslyn & Uhl-Bien (2001). Response scales vary and are listed above with the corresponding item.

APPENDIX F

THE HYPOTHESIZED MODEL WITH ALL PATHS DEPICTED

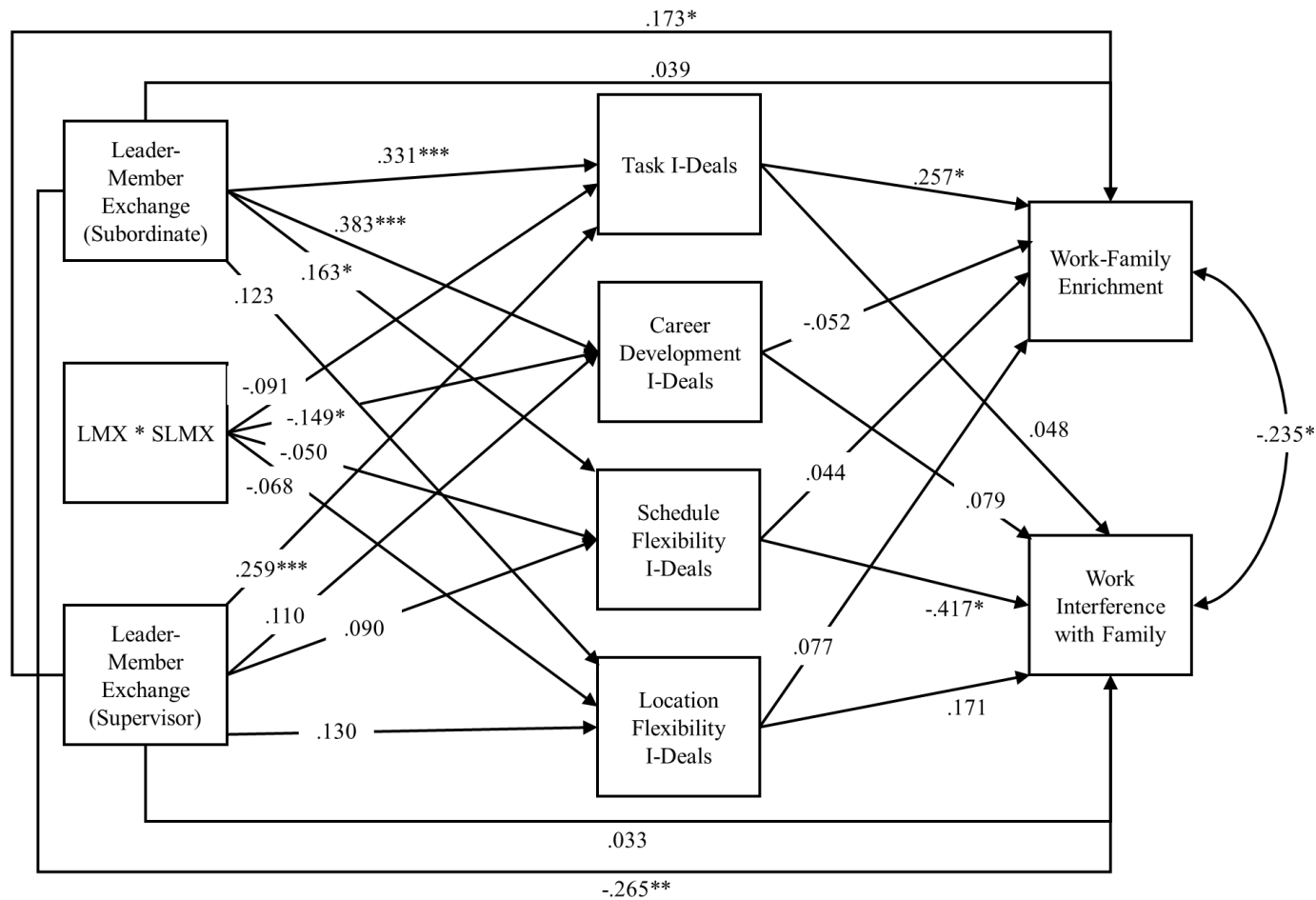

Note: The hypothesized model (without control variables) with standardized parameter estimates. * $p < .05$, ** $p < .01$, *** $p < .001$.

APPENDIX G

THE HYPOTHESIZED MODEL CONTROLLED FOR WORK HOURS PER WEEK

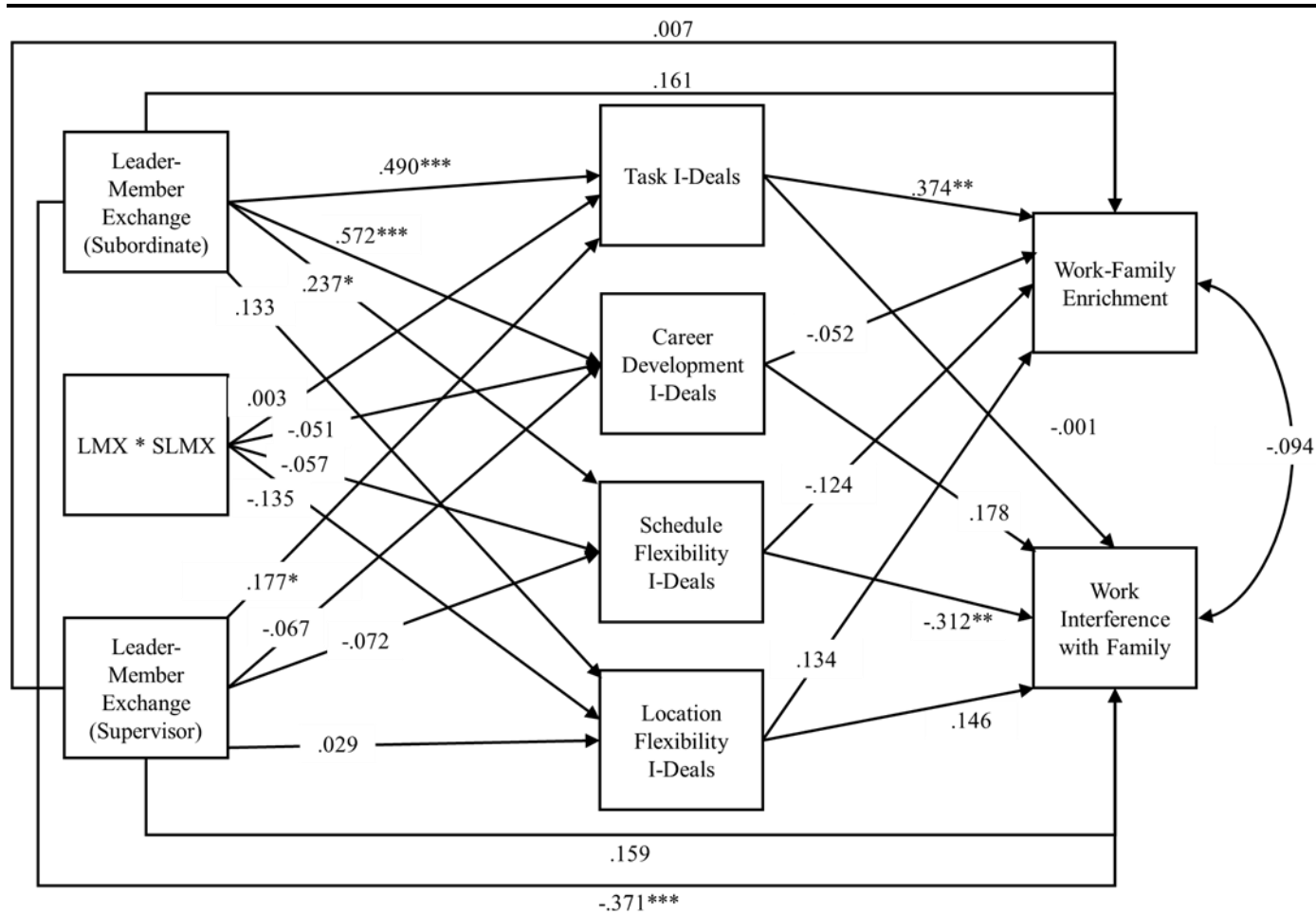

Note: The hypothesized model controlled for average work hours per week with standardized parameter estimates. * $p < .05$, ** $p < .01$, *** $p < .001$.

VITA

Michael L. Litano received his Bachelor of Science degree in Kinesiology from the University of Massachusetts, Amherst in May of 2009, his Master of Arts degree in Psychology in May of 2012 from Boston University, his Master of Science degree in Industrial-Organizational Psychology from Old Dominion University in December 2014, and his Doctor of Philosophy in Industrial-Organizational Psychology from Old Dominion University in May 2017. While enrolled at Old Dominion University, Michael worked as a researcher in the Career Development Laboratory, and was promoted from graduate research assistant to project manager for a large-scale research grant funded by the National Science Foundation. In addition, he worked as an Organizational Research Science intern for NASA Langley Research Center for 18 months. In February 2017, he became employed as a Principal Associate on Capital One's People Analytics team in McLean, Virginia. Michael has published his research in top-tier applied psychology journals, including *The Leadership Quarterly*, the *Journal of Business and Psychology*, the *Journal of Career Development*, and *The Oxford Handbook of Work and Family*, among numerous other publications.

The address for the Department of Psychology at Old Dominion University is 250 Mills Godwin Building, Norfolk, VA 23529.